



## **04** Flatbed Superstructures



# SIDEBOARD PROFILES 25 mm - LOWER

Lower profile 100 mm			
TT-number	Surface	Material	Weight
0411001.000	natural	AlMgSi0,5	1.60 kg/m
0412001.000	anodized		

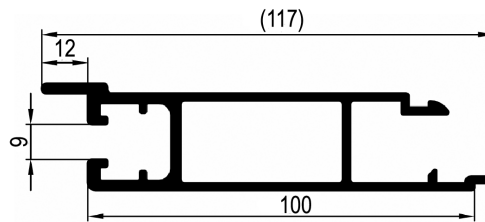

Lower profile 100 mm, for seals			
TT-number	Surface	Material	Weight
0411002.000	natural	AlMgSi0,5	1.60 kg/m
0412002.000	anodized		

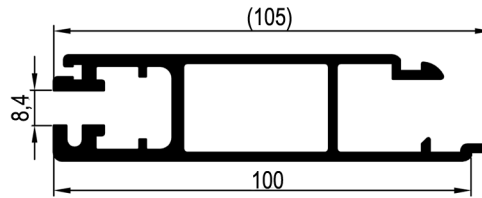

Lower profile 200 mm			
TT-number	Surface	Material	Weight
0411003.000	natural	AlMgSi0,5	2.67 kg/m
0412003.000	anodized		

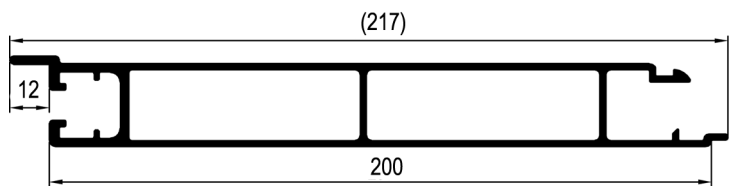

Lower profile 200 mm, for seals			
TT-number	Surface	Material	Weight
0411004.000	natural	AlMgSi0,5	2.67 kg/m
0412004.000	anodized		

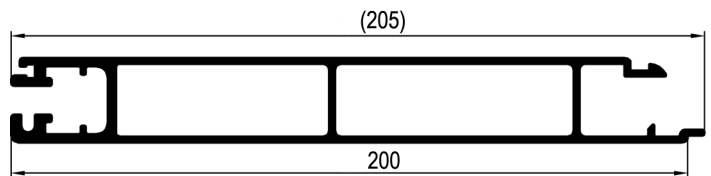

Lower profile 215 mm, for seals			
TT-number	Surface	Material	Weight
0411007.000	natural	AlMgSi0,5	2.71 kg/m

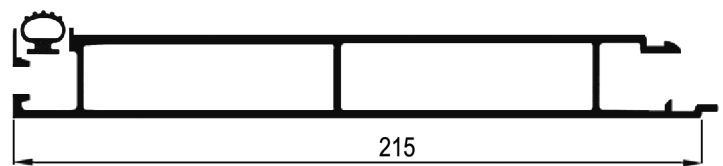

Sideboard seals		
TT-number	Material	Weight
0612040.000	rubber	0.165 kg/m

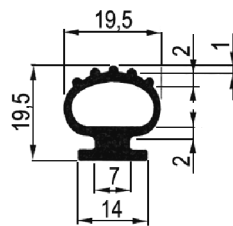

Sideboard seals		
TT-number	Material	Weight
0413002.000	PVC	0.10 kg/m

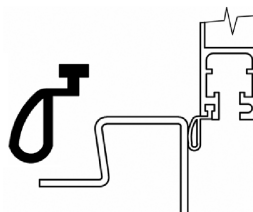

Stop and sealing profile		
TT-number	Material	Weight
0413001.000	rubber	0.78 kg/m

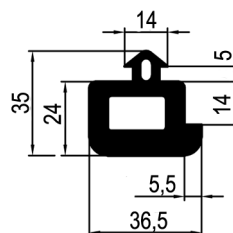

# SIDEBORD PROFILES 25 mm - MIDDLE

## Middle profile 200 mm

TT-number	Surface	Material	Weight
0411024.000	natural	AlMgSi0,5	1.90 kg/m
0412024.000	anodized		

## Middle profile 200 mm

TT-number	Surface	Material	Weight
0411026.000	natural	AlMgSi0,5	2.53 kg/m
0412026.000	anodized		

## Middle tarpaulin profile 200 mm

TT-number	Surface	Material	Weight
0411027.000	natural	AlMgSi0,5	2.10 kg/m
0412027.000	anodized		

## Middle profile 200 mm for rails

TT-number	Surface	Material	Weight
0411030.000	natural	AlMgSi0,5	2.63 kg/m

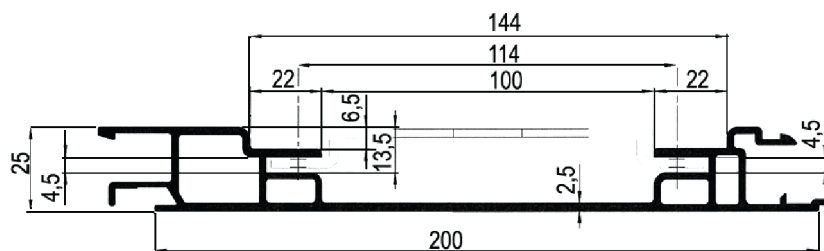
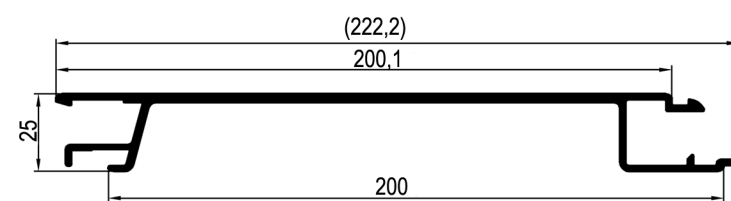
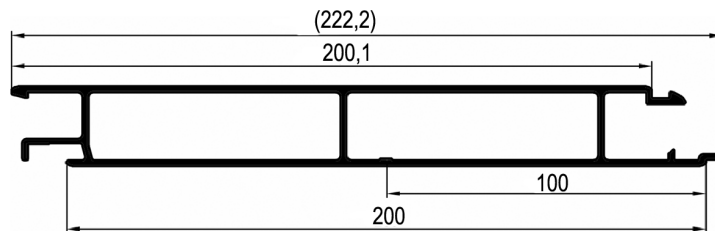
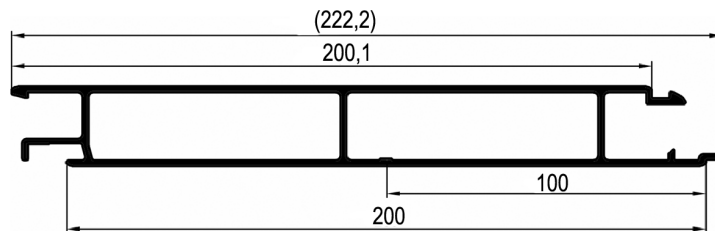

# SIDEBORD PROFILES 25 mm - TOP

Upper profile 200 mm			
TT-number	Surface	Material	Weight
0411051.000	natural	AlMgSi0,5	2.52 kg/m
0412051.000	anodized		

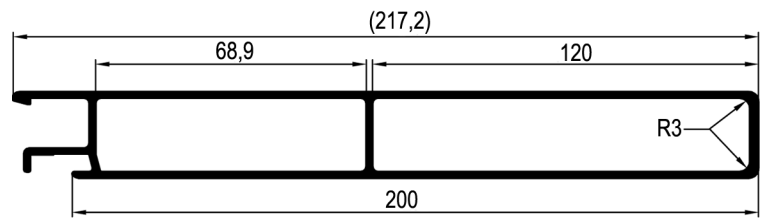

Top tarpaulin profile 200 mm			
TT-number	Surface	Material	Weight
0411053.000	natural	AlMgSi0,5	2.38 kg/m
0412053.000	anodized		

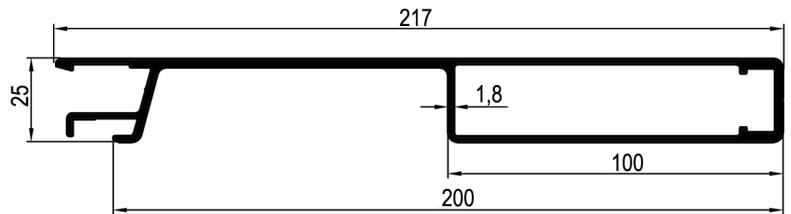

Top profile 200 mm for rail			
TT-number	Surface	Material	Weight
0411057.000	natural	AlMgSi0,5	2.6 kg/m

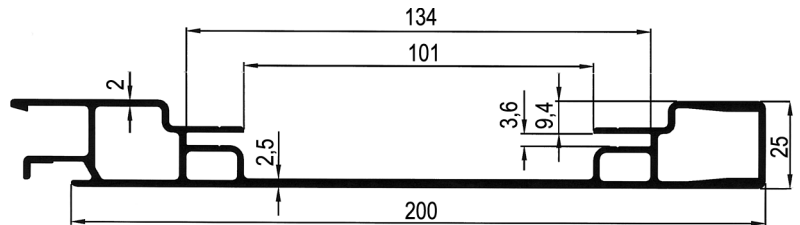

Upper profile 100 mm			
TT-number	Surface	Material	Weight
0411054.000	natural	AlMgSi0,5	1.59 kg/m
0412054.000	anodized		

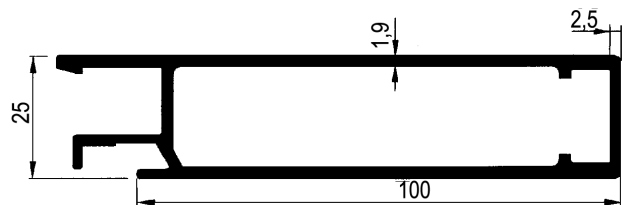

Upper profile 50 mm			
TT-number	Surface	Material	Weight
0411055.000	natural	AlMgSi0,5	0.96 kg/m

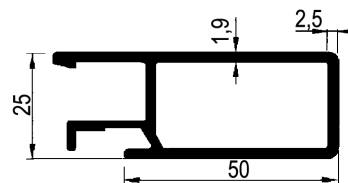

Tarpaulin profile 400 mm			
TT-number	Surface	Material	Weight
0412101.000	anodized	AlMgSi0,5	4.25 kg/m

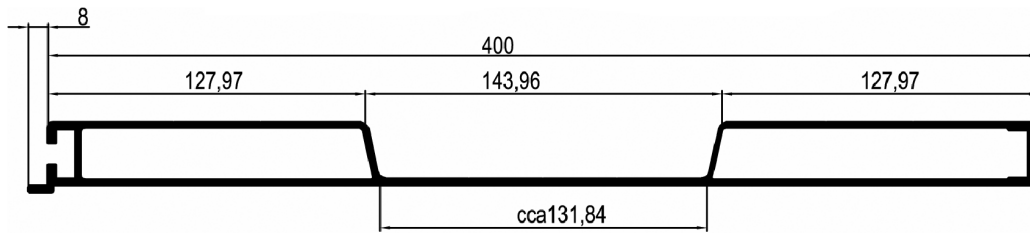

Tarpaulin profile 350 mm			
TT-number	Surface	Material	Weight
0412109.000	anodized	AlMgSi0,5	3.6 kg/m

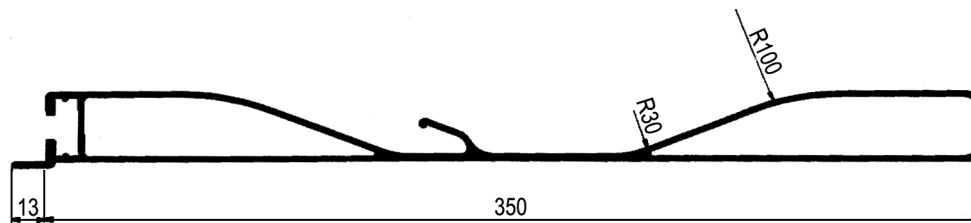

Tarpaulin profile 400 mm for hooks, reinforced			
TT-number	Surface	Material	Weight
0412103.000	anodized	AlMgSi0,5	4.26 kg/m

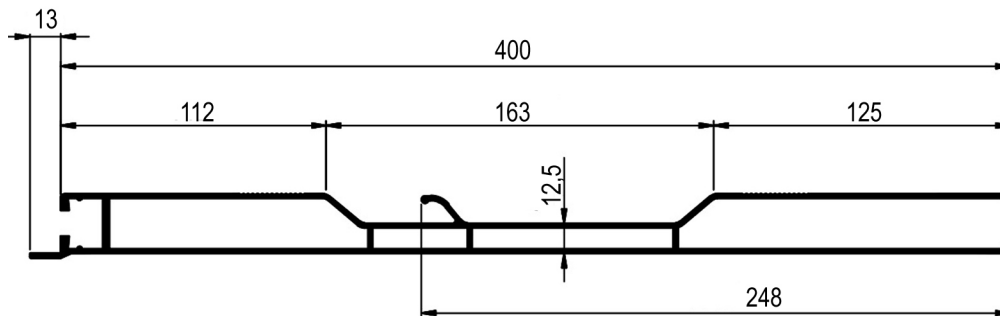

Hook for tarpaulin and profiles			
TT-number	Surface	Material	Weight
0413102.000	nylon	black	0.01 kg/pc

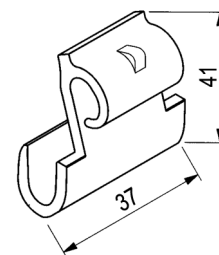

## SIDEBORD PROFILES 25 mm

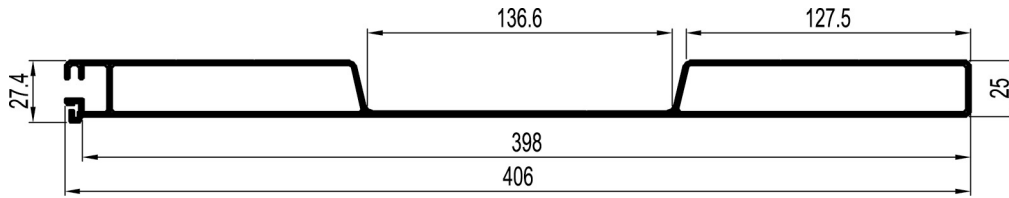

Tarpaulin profile 406 mm			
TT-number	Surface	Material	Weight
0411104.000	natural	AlMgSi0,5	4.25 kg/m
0412104.000	anodized		



# SIDEBORD PROFILES 25 mm

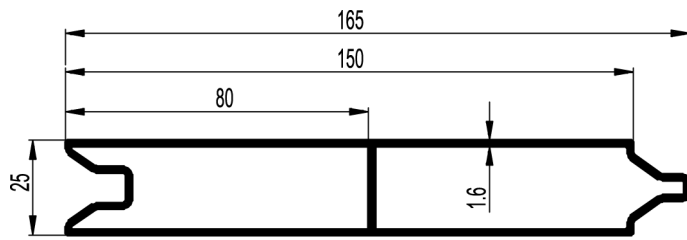

Profile 150 mm

TT-number	Surface	Material	Weight
0411091.000	natural	AlMgSi0,5	1.7 kg/m
0412091.000	anodized		

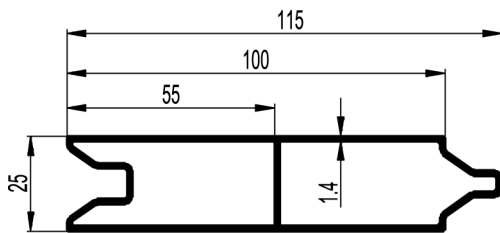

Profile 100 mm

TT-number	Surface	Material	Weight
0411092.000	natural	AlMgSi0,5	1.1 kg/m

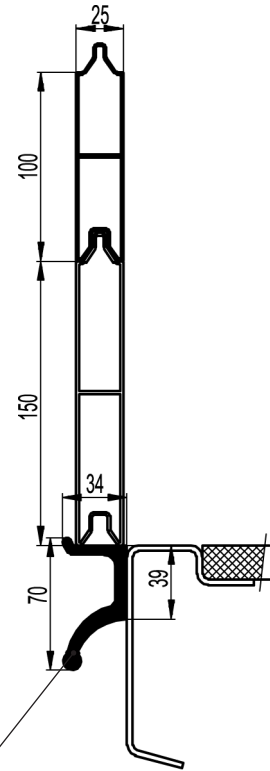

0521405.000





# UNDER-TARPAULIN PROFILES 25 mm

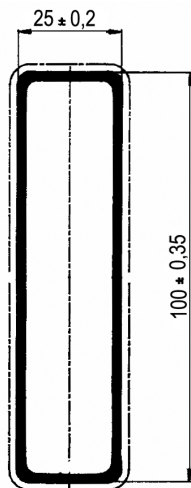

0411093.000

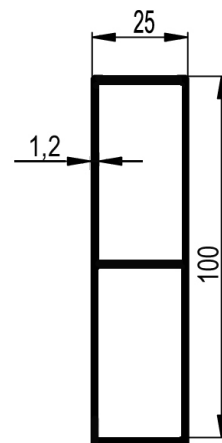
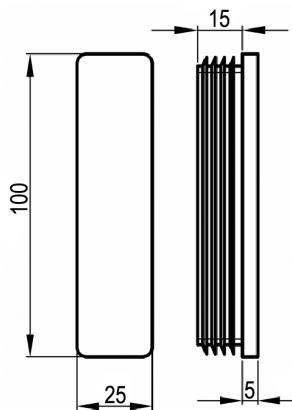

0411094.000

TT-number	Name	Material	Weight
0411093.000	Under-tarpaulin profile 100 x 25	aluminium	1.18 kg/m
0413093.000	Profile stopper 100 x 25	PU	0.08 kg/pc
0411094.000	Under-tarpaulin profile 100 x 25, lightweight with bulkhead	aluminium	0.87 kg/m
0412094.000	Under-tarpaulin profile 100 x 25, lightweight with bulkhead	Al anodized	0.87 kg/m



## Edging profile U

TT-number	Surface	Material	Weight
0411072.000	natural	AlMgSi0,5	0.70 kg/m
0412072.000	anodized		

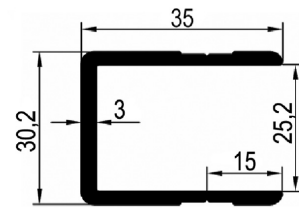

## Edging profile h

TT-number	Surface	Material	Weight
0411073.000	natural	AlMgSi0,5	0.87 kg/m
0412073.000	anodized		

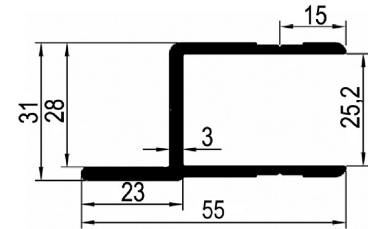

## Edging profile for latch with edging

TT-number	Surface	Material	Weight
0411078.000	natural	AlMgSi0,5	1.25 kg/m
0412078.000	anodized		

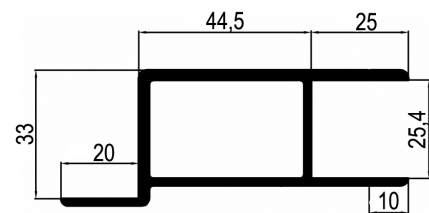

## Edging profile for latch without edging

TT-number	Surface	Material	Weight
0411079.000	natural	AlMgSi0,5	1.24 kg/m
0412079.000	anodized		

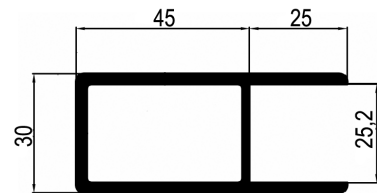

## Side edging profile (Ital 2000)

TT-number	Surface	Material	Weight
0412080.000	anodized	AlMgSi0,5	0.86 kg/m
0413080.000	seals	rubber, black	0.05 kg/m

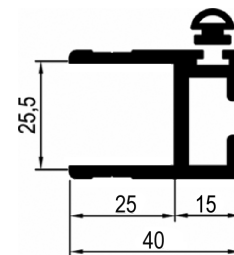

# SIDEBOARD EDGING PROFILES 25 mm

## Side edging profile K20 (Kinnegrip)

TT-number	Surface	Material	Weight
0411082.000	natural	AlMgSi0,5	1.29 kg/m
0412082.000	anodized		

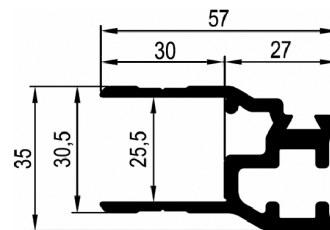

## Rear edging profile K20 (Kinnegrip)

TT-number	Surface	Material	Weight
0411083.000	natural	AlMgSi0,5	1.22 kg/m
0412083.000	anodized		

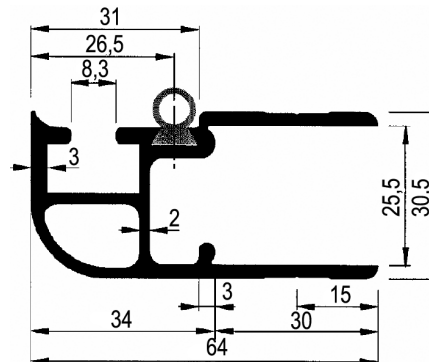

## Edging profile (for latch Hestál 681)

TT-number	Surface	Material	Weight
0411084.000	natural	AlMgSi0,5	1.00 kg/m
0412084.000	anodized		

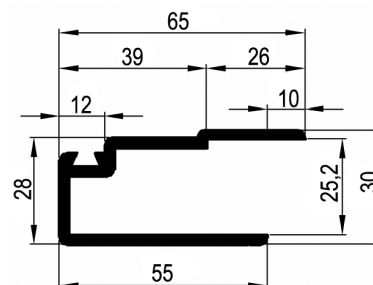

## Edging seal 080 / 081 (Ital 200)

TT-number	Material	Weight
0413080.000	rubber, black	0.05 kg/m

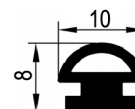

## Seal K 20 for edging (082 / 083 / 084)

TT-number	Material	Weight
0413082.000	rubber, black	0.06 kg/m



## Rubber stopper for edging (078 / 079)

TT-number	Material	Weight
0413078.000	rubber, black	0.02 kg/pc

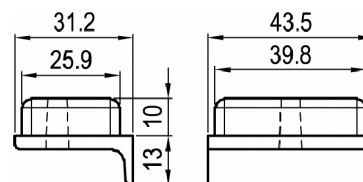

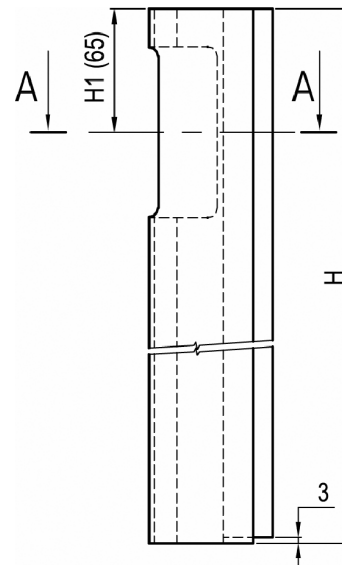
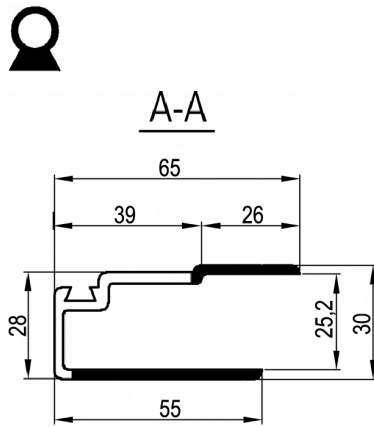

Left design

Edging profile for latch Hestal 681 S - TT 0423015.000

TT-number natural	TT-number anodized	Height H [mm] design	Axis of H1 latch mm	Weight kg/pc
0411084.401	0412084.401	400 L	65	0.35
0411084.402	0412084.402	400 R	65	0.35
0411084.411	0412084.411	405 L	65	0.40
0411084.412	0412084.412	405 R	65	0.40
0411084.501	0412084.501	500 L	65	0.45
0411084.502	0412084.502	500 R	65	0.45
0411084.601	0412084.601	600 L	65	0.55
0411084.602	0412084.602	600 R	65	0.55
0411084.801	0412084.801	800 L	65	0.75
0411084.802	0412084.802	800 R	65	0.75



# SIDBOARD LATCHES EDGING TYPE PO

Material: Al

Sideboard latches without edging, with plastic safety lock		
TT-number anodized	Latch height design	Weight kg/pc
0422125.411	405 L	1.30
0422125.412	405 R	1.30
0422125.501	500 L	1.35
0422125.502	500 R	1.35
0422125.601	600 L	1.45
0422125.602	600 R	1.45
0422125.801	800 L	1.65
0422125.802	800 R	1.65

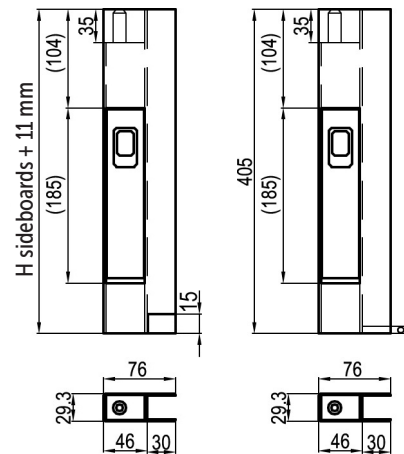

0422125.401  
0422125.501  
0422125.601  
0422125.401

0422125.411

Sideboard latches without edging without plastic safety lock		
TT-number anodized	Latch height design	Weight kg/pc
0422124.411	405 L	0.7
0422124.412	405 R	0.7

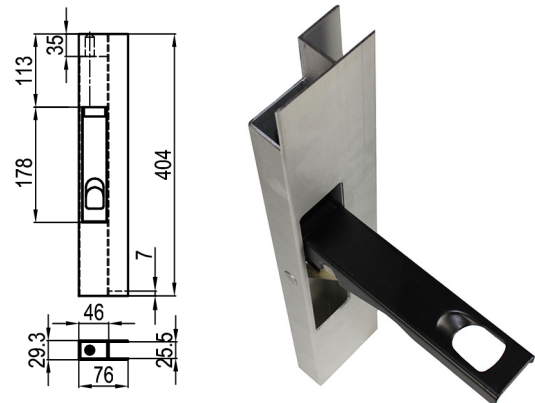

0422124.411



# SIDEBOARD LATCHES WITH EDGING

Material: Al

## Sideboard latches with edging and safety lock

TT-number natural	TT-number anodized	Latch height design	Weight kg/pc
0421100.401	0422100.401	400 L	1.25
0421100.402	0422100.402	400 R	1.25
0421100.501	0422100.501	500 L	1.35
0421100.502	0422100.502	500 R	1.35
0421100.601	0422100.601	600 L	1.45
0421100.602	0422100.602	600 R	1.45
0421100.801	0422100.801	800 L	1.65
0421100.802	0422100.802	800 R	1.65

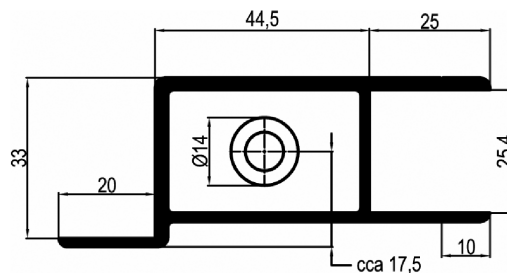

## Sideboard latches without edging with safety lock

TT-number natural	TT-number anodized	Latch height design	Weight kg/pc
0421110.411	0422110.411	400L	1.27
0421110.412	0422110.412	400P	1.27
0421110.501	0422110.501	500 L	1.35
0421110.502	0422110.502	500 R	1.35
0421110.601	0422110.601	600 L	1.45
0421110.602	0422110.602	600 R	1.45
0421110.801	0422110.801	800 L	1.65
0421110.802	0422110.802	800 R	1.65

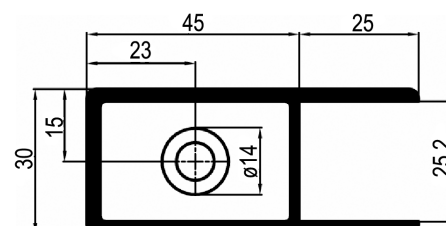

### 0413078.000

**Rubber stopper** for sideboard latches, applicable to types: 0422100, 0422110, 0422120, Weight: 0.05 kg/pc

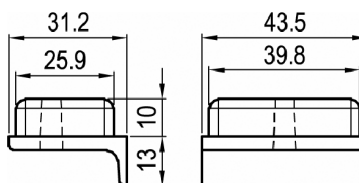

### 0421112.000

**Euroclip lock mechanism** applicable to types: 0422100, 0422110, Material: galvanized steel Weight: 0.8 kg/pc

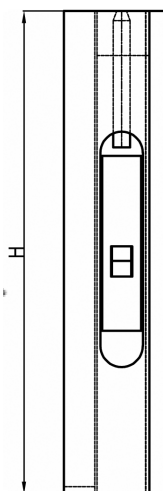

Rivets are used as standard to fasten the edges and latches with sideboard profiles: Al / St 4.8 x 10, order number 2111148.101

# SIDEBOARD LATCHES 1 PLUS TYPE AG

Sideboard latches applicable to the pillarless design for the front face. A combination of a latch and a riveting piece placed on the frame (pillar) of the front face will be used.

Material: aluminium anodised

LATCH

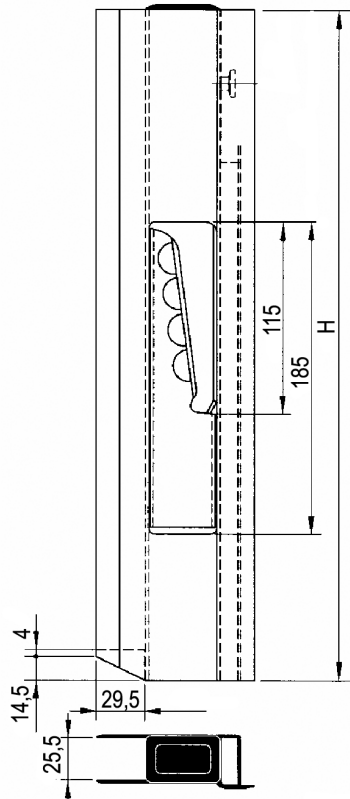

RIGHT DESIGN

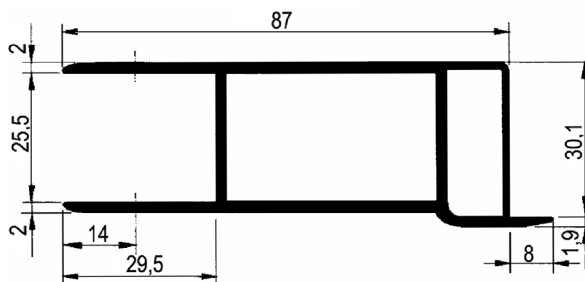

Riveting piece  
0422220.000

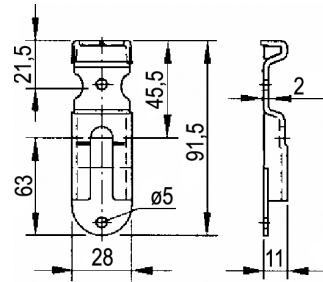

Sideboard height mm	H mm	Latch			Riveting piece	
		left	right	Weight kg/pc	TT-number	Weight kg/pc
		TT-number	TT-number			
400	410	0422225.401	0422225.402	0.90	0422220.000	0.05

# SIDEBOARD EDGING LATCHES 1 PLUS TYPE EG

Sideboard latches applicable for jointless design of rear face and sideboard by means of latch and counterpart.  
Material: aluminium anodised

LATCH

riveting piece  
042220.000

COUNTERPART

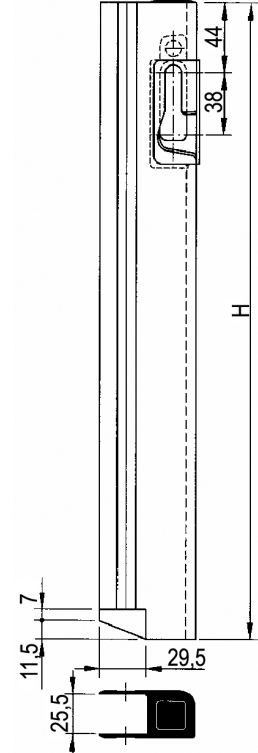
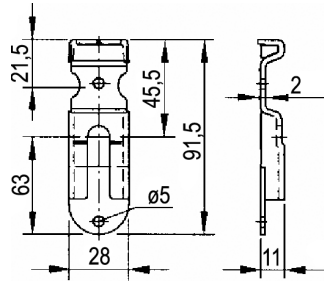
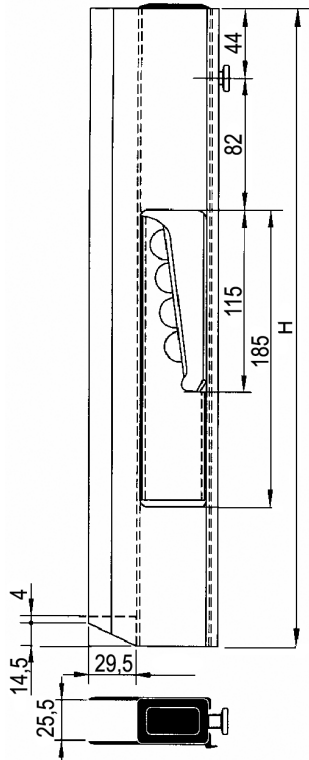

RIGHT DESIGN

RIGHT DESIGN

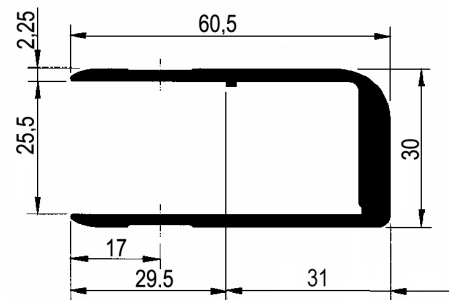
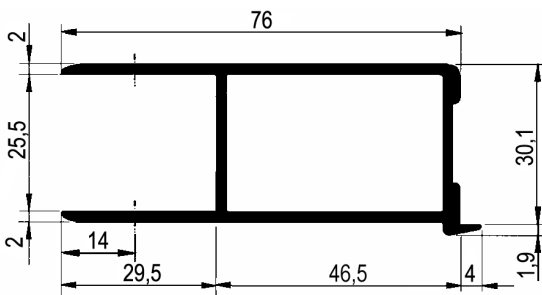

Sideboard height mm	H mm	Latch			Counterpart			Riveting piece	
		left	right	Weight kg/pc	left	right	Weight kg/pc	TT-number	Weight kg/pc
		TT-number	TT-number		TT-number	TT-number			
300	310	0422226.301	0422226.302	0.77	0422226.303	0422226.304	0.40	0422220.000	0.05
400	410	0422226.401	0422226.402	0.90	0422226.403	0422226.404	0.40		
500	510	0422226.501	0422226.502	1.0	0422226.503	0422226.504	0.5		
600	610	0422226.601	0422226.602	1.07	0422226.603	0422226.604	0.55		





# SIDEBOARD LATCHES WITHOUT EDGING

## 0422129.411

### Sideboard latch without edging, left

Material: Al anodized

Weight: 1.45 kg/pc

## 0422129.412

### Sideboard latch without edging, right

Material: Al anodized

Weight: 1.45 kg/pc

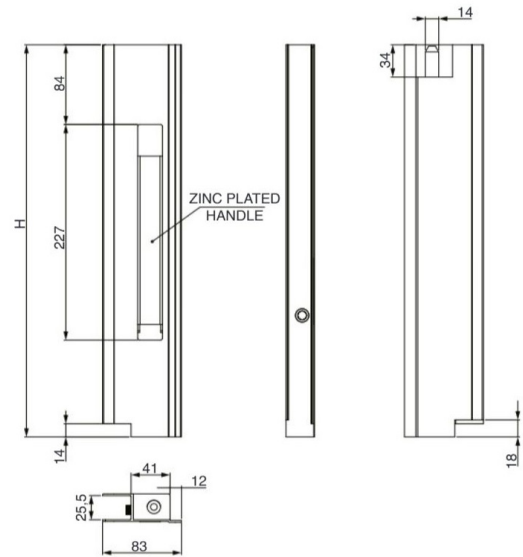

## SIDEBOARD PROFILES 30 mm - BOTTOM, MIDDLE

### Bottom profile 220 / 30 mm

TT-number	Surface	Material	Weight kg/m
0411301.000	natural	AlMgSi0,5	3.72

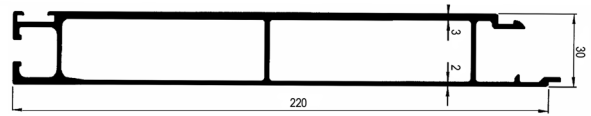

### Middle profile 200 / 30 mm

TT-number	Surface	Material	Weight
0411328.000	natural	AlMgSi0,5	3.52 kg/m

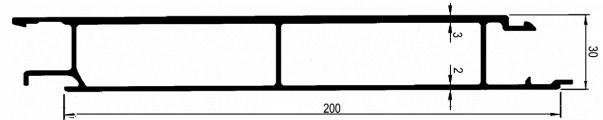

### Edging seal

TT-number	Material	Weight
0413004.000	rubber, black	0.08 kg/m



## SIDEBOARD PROFILES 30 mm - UPPER

### Upper profile 200 / 30 mm

TT-number	Surface	Material	Weight
0411351.000	natural	AlMgSi0,5	3.76 kg/m

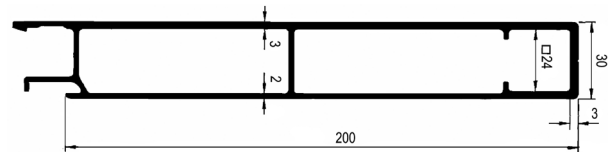

### Upper profile 200 / 30 mm, for pin 25

TT-number	Surface	Material	Weight
0411350.000	natural	AlMgSi0,5	4.54 kg/m

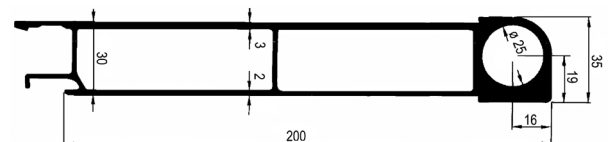

## SIDEBOARD EDGING PROFILES 30 mm

### Edging profile U

TT-number	Surface	Material	Weight
0411380.000	natural	AlMgSi0,5	0.81 kg/m

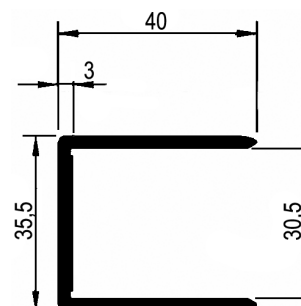

# SIDEBOARD PROFILES 40 mm - LOWER

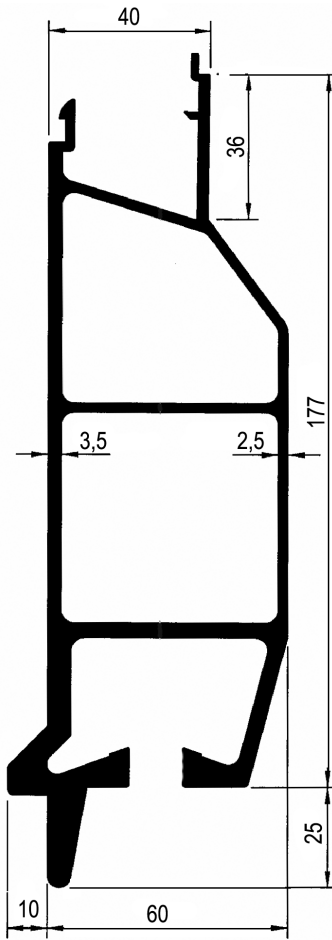

**0411402.000**

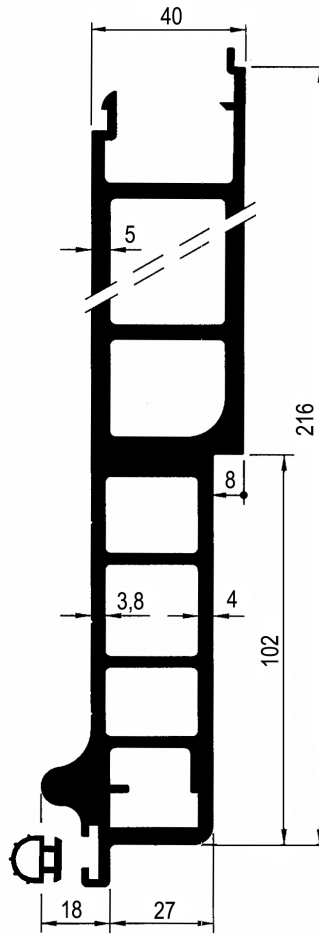

**0411401.000**

hinge type H 659 can be used  
**0712011.000**

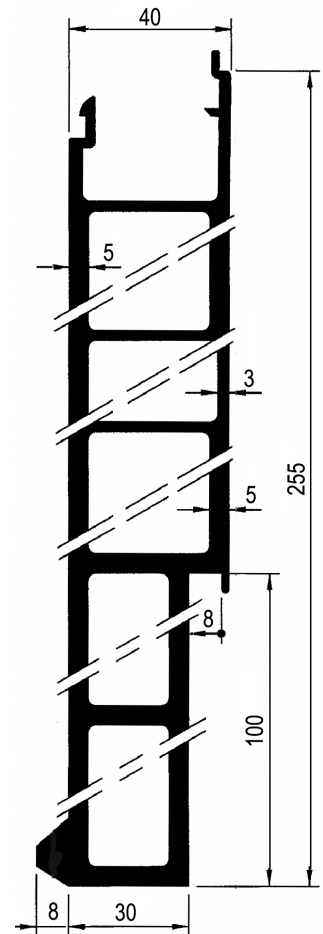

**0411400.000**

hinge type H 659 can be used  
**0712011.000**

## Lower profile 40 mm

TT-number	Surface	Material	Weight kg/m
<b>0411402.000</b>	natural	AlMgSi 0.7	6.21
<b>0411401.000</b>	natural	AlMgSi 0.7	8.38
<b>0411400.000</b>	natural	AlMgSi 0.7	8.68

## Edging seal

TT-number	Material	Weight
<b>0413005.000</b>	rubber, black r	0.02 kg/m



# SIDEBORD PROFILES 40 mm - MIDDLE

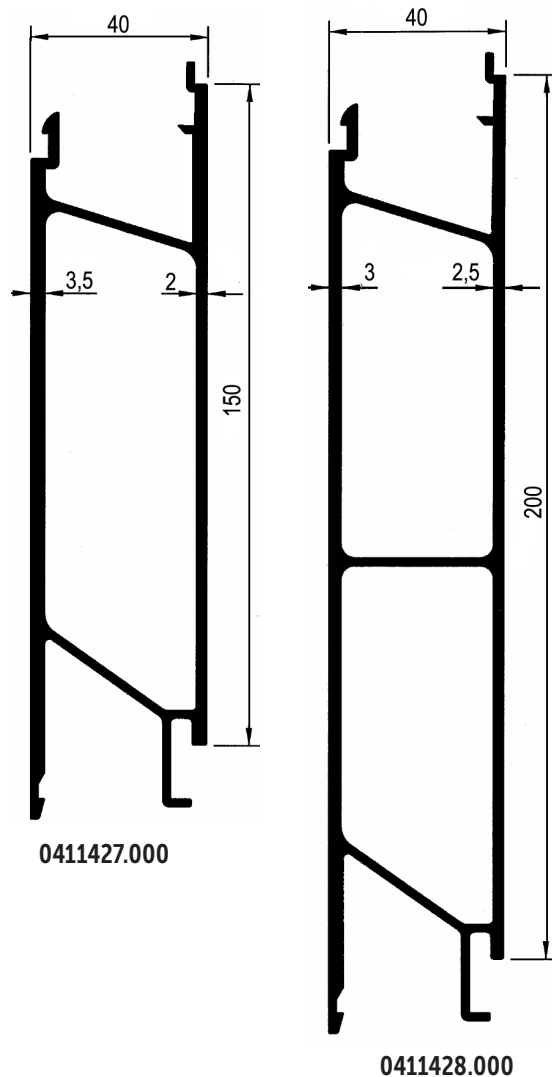

Middle profile 150 / 40 mm			
TT-number	Surface	Material	Weight
0411427.000	natural	AlMgSi 0.7	3.19 kg/m
Middle profile 200 / 40 mm			
TT-number	Surface	Material	Weight
0411428.000	natural	AlMgSi 0.7	4.20 kg/m



# SIDEBOARD PROFILES 40 mm - UPPER

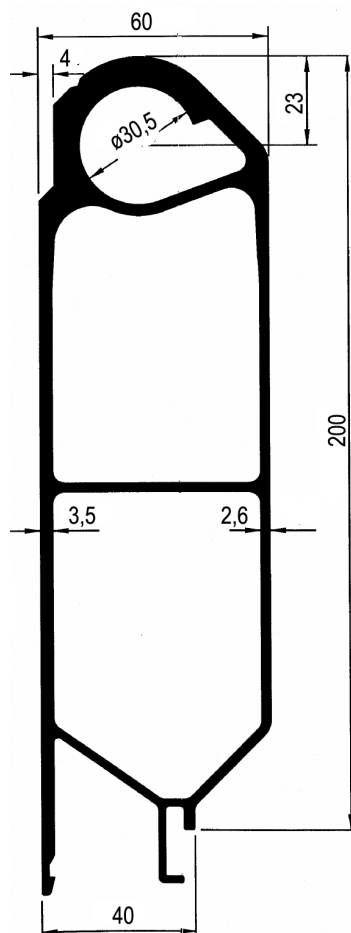

0411453.000

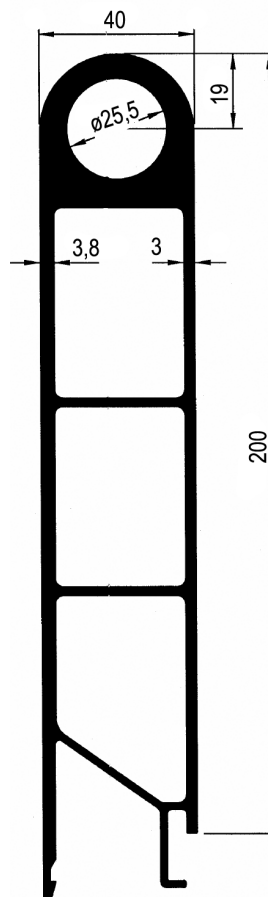

0411452.000

Extended upper profile 200 / 40 mm, for pin 30			
TT-number	Surface	Material	Weight
0411453.000	natural	AlMgSi 0.7	6.33 kg/m
Upper profile 200 / 40 mm, for pin 25			
TT-number	Surface	Material	Weight
0411452.000	natural	AlMgSi 0.7	6.62 kg/m





Edging profile U			
TT-number	Surface	Material	Weight
0411476.000	natural	AlMgSi 0.7	2.49 kg/m

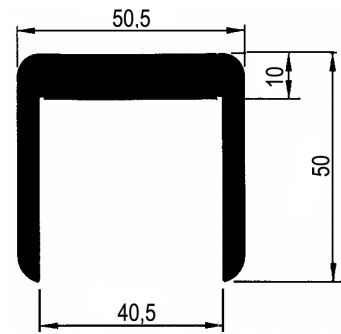

Side edging profile			
TT-number	Surface	Material	Weight
0411477.000	natural	AlMgSi 0.7	2.61 kg/m

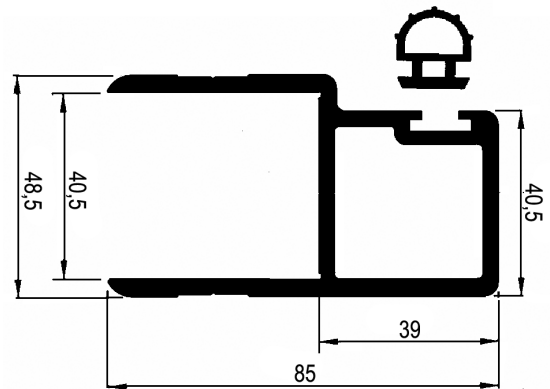

Edging seal		
TT-number	Material	Weight
0413005.000	rubber, black	0.02 kg/m



Al edging profile 60x20 mm			
TT-number	Surface	Material	Weight
0411472.000	natural	EN AW 6005	3.26 kg/m

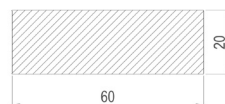

# RECESSED SIDEBOARD LATCHES 25 mm

## 0423010.010

### Counterpart to "T" latch

Material: galvanized steel

Weight: 0.19 kg/pc

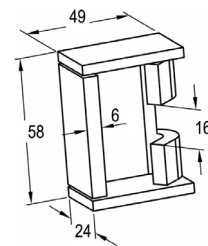

## 0423010.000

### Recessed sideboard latch

with adjustable T-bar.

Material: galvanized steel

Weight: 1.46 kg/pc

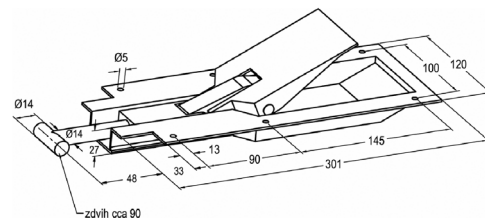
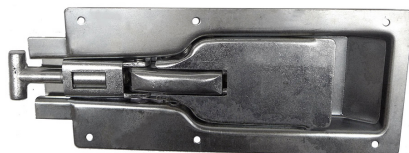

## 0423011.000

### Recessed sideboard latch

Material: galvanized steel

Weight: 1.1 kg/pc

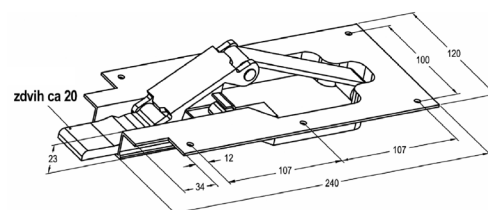
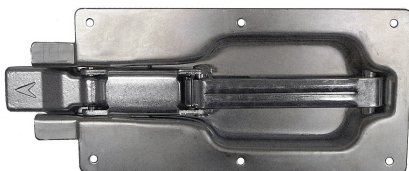

# SIDEBOARD LATCHES RECESSED PESCA, FOR SIDEBOARDS 25 mm

**0423012.000**

**PESCA recessed sideboard latch,  
type 694 B**

including the counterpart

Material: galvanized steel

Weight: 1.43 kg/pc

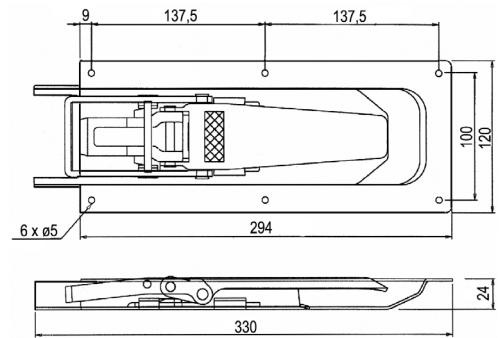
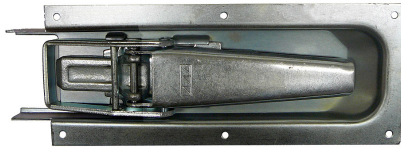



# SIDEBOARD LATCHES. RECESSED HESTAL, FOR SIDEBOARD 25 mm

## 0423015.000

### Recessed sideboard latch HESTAL, type 681 S/1

With adjustable T-bar

Material: galvanized steel

Weight: 1.57 kg/pc

## 0423015.010

### Counterpart for latch type 6817

Material: steel

Weight: 0.21 kg/pc

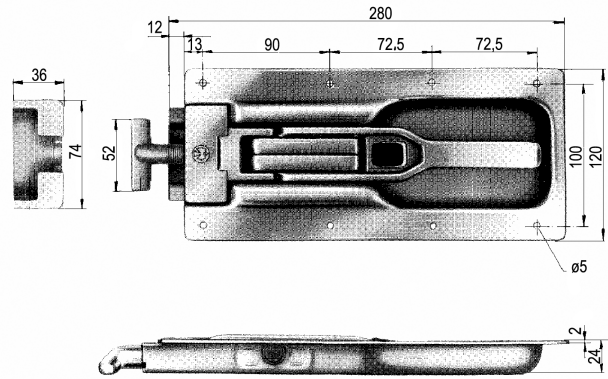
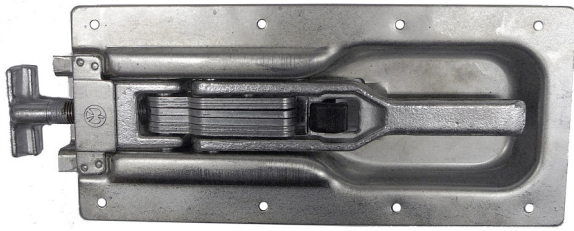

# RECESSED SIDEBOARD LATCHES 25 mm

## 0423018.000

### Recessed sideboard latch

With adjustable T-bar

Material: galvanized steel

Weight: 1.62 kg/pc

## 0423018.010

### Counterpart for pillar

Material: steel

Weight: 0.16 kg/pc

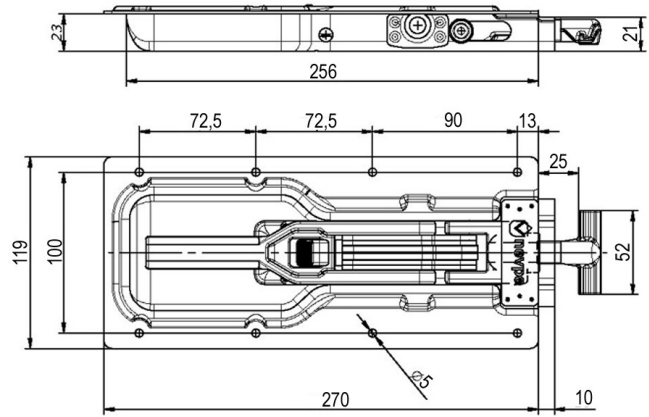
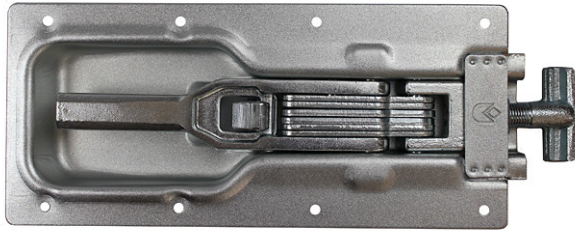

# RECESSED SIDEBOARD LATCHES 25 mm

**0423021.000**

**Recessed sideboard latch PWP, type 2001**

Material: galvanized steel

Weight: 0.75 kg/pc

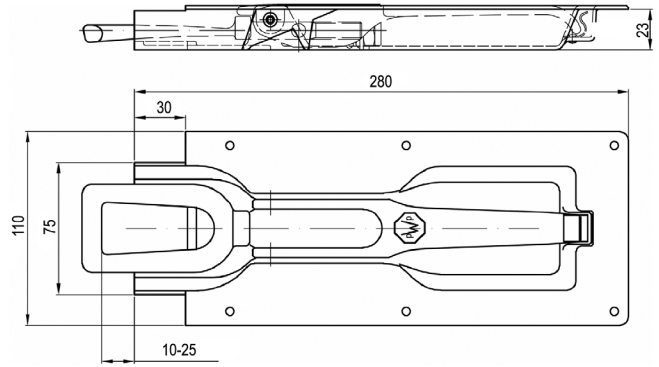
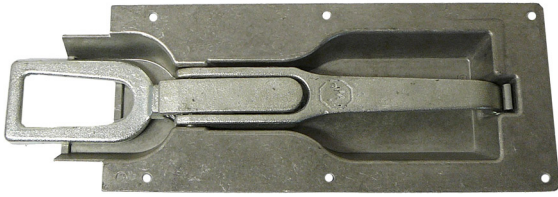

**0423022.000**

**Recessed sideboard latch PWP, type 2002**

Material: galvanized steel

Weight: 0.78 kg/pc

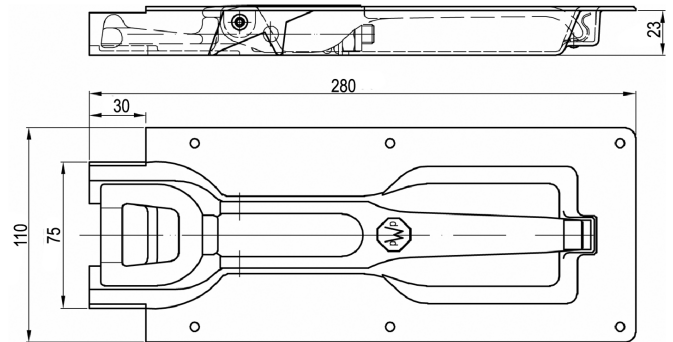
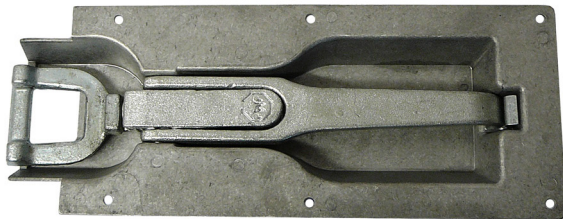

**0423021.010**

**Straight screw-in counterpart**

Material: galvanized steel

Weight: 0.18 kg/pc

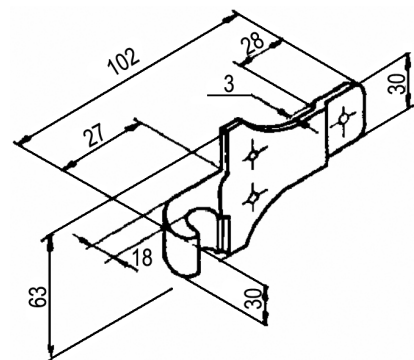

# EXTERNAL SIDEBOARD LATCHES

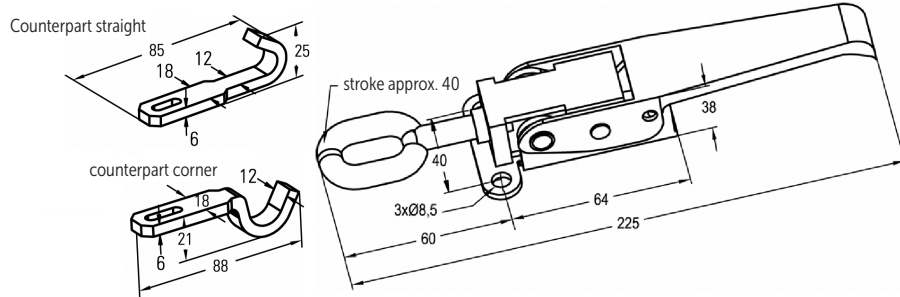

TT-number	Name	Material	Weight kg/pc
0423101.000	Sideboard latch eccentric, adjustable bar	galvanized steel	0.32
0423101.010	Counterpart straight	steel	0.06

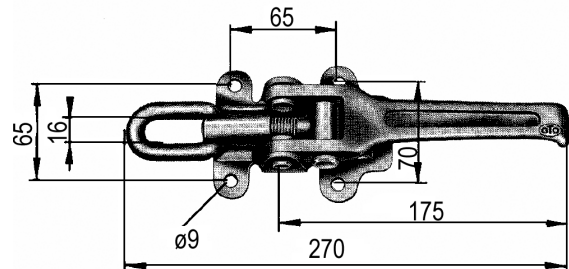
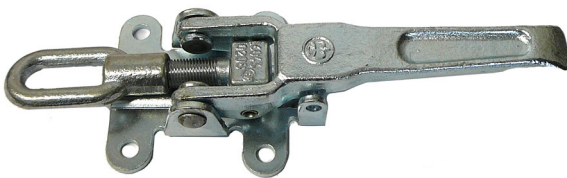

TT-number	Name	Material	Weight kg/pc
0423103.000	Eccentric sideboard latch, adjustable	galvanized steel	0.54
0423104.100	Eccentric adjustable sideboard latch with safety lock	steel	0.2



# EXTERNAL SIDEBOARD LATCHES

**0423111.000**

**External sideboard latch PWP, type 1001**

Material: galvanized steel

Weight: 0.90 kg/pc

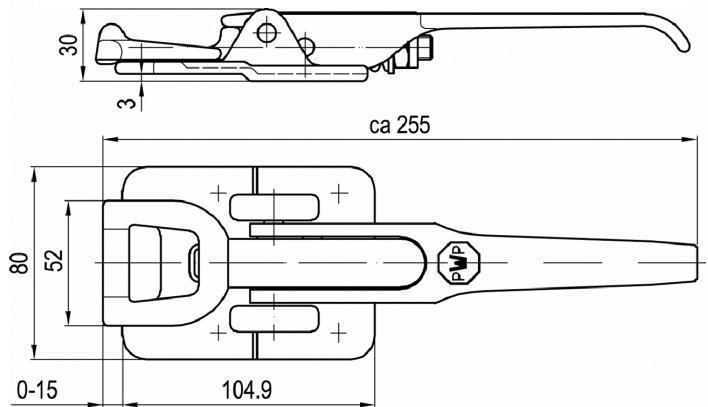
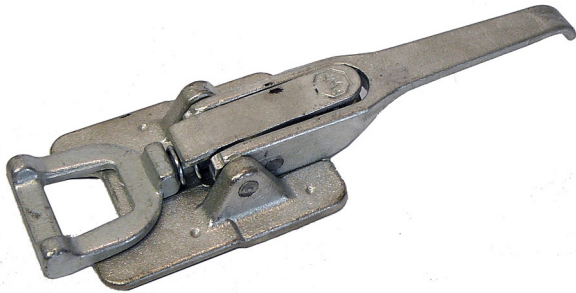

**0423112.000**

**External sideboard latch PWP, type 1002**

Material: galvanized steel

Weight: 0.94 kg/pc

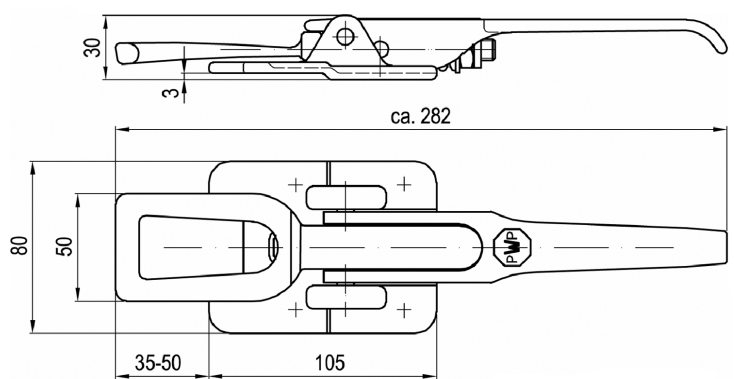
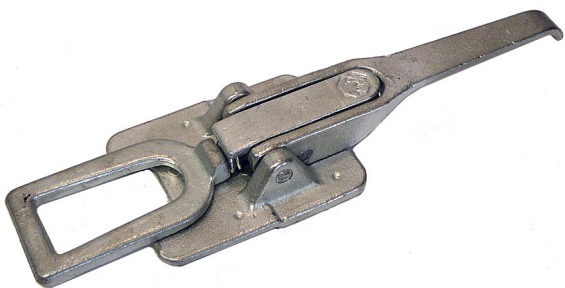

**0423111.010**

**Angled screwdriving counterpart**

Material: galvanized steel

Weight: 0.15 kg/pc

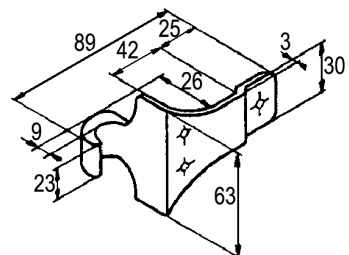

# SIDEBOARD LATCHES - (END HOOKS)

## Sideboard latch, size 0 (end hook)

Material: galvanized steel  
Construction height: 28 mm

TT-number	Name	Eye size	Weight kg/pc
0423151.000	Sideboard latch left	0	0.33
0423152.000	Sideboard latch right	0	0.33

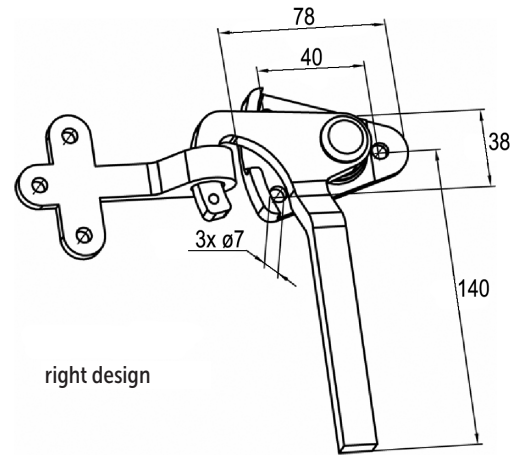

## Sideboard latch, size 1 (end hook)

with safety pin  
Material: galvanized steel  
Construction height: 45 mm

TT-number	Name	Eye size	Weight kg/pc
0423161.000	Sideboard latch left with locking safety pin	1	0.96
0423162.000	Sideboard latch, right hand, with locking safety pin	1	0.96

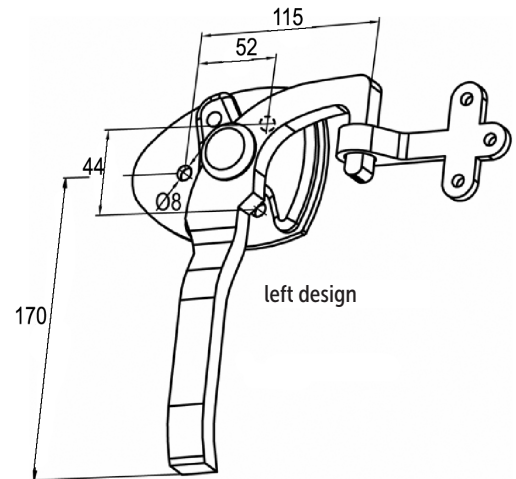

## Sideboard latch, size 3 (end hook)

Material: galvanized steel  
Construction height: 45 mm

TT-number	Name	Eye size	Weight kg/pc
0423163.000	Sideboard latch left	3	0.64
0423164.000	Sideboard latch right	3	0.64

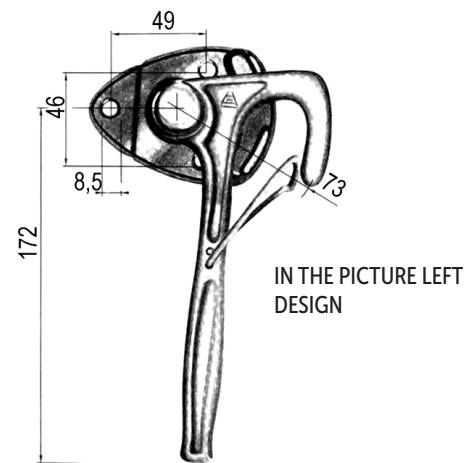

## Eye for sideboard latches - screw-in

Material: galvanized steel  
Construction height: 45 mm

TT-number	eye size	D mm	E mm	F mm	G mm	Weight kg/pc
0423155.000	0	75	42	12	6.5	0.11
0423156.000	1	100	50	16	8.5	0.24
0423157.000	3		50	16		0.19

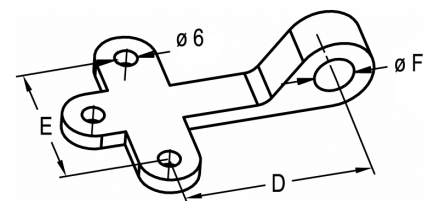

## OTHER LATCHES AND ACCESSORIES

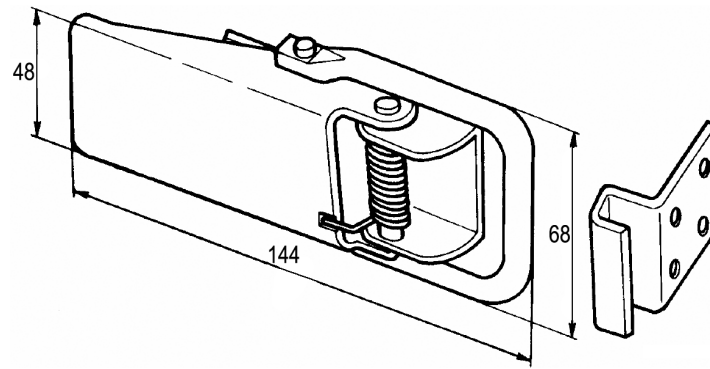

TT-number	Name	Material	Weight kg/pc
0423130.000	Box latch without counterpart	galvanized steel	0.35
0423130.010	Counterpart to box latch	galvanized steel	0.08

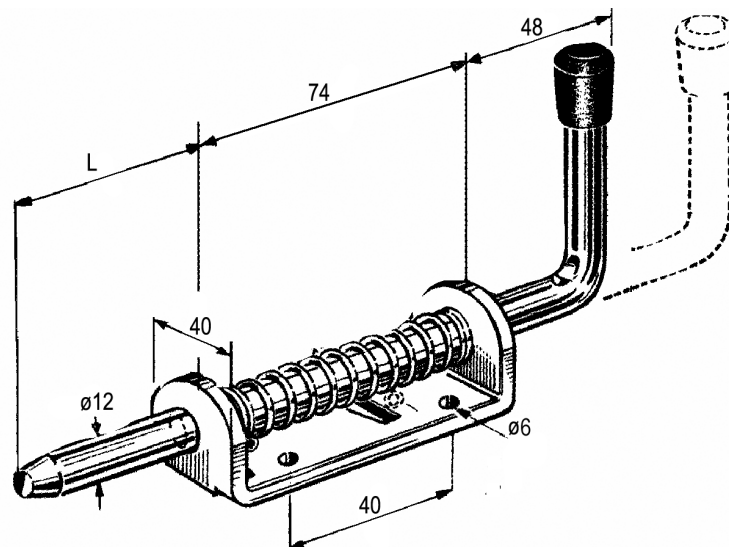

TT-number	Material	Length L mm	Weight kg/pc
0423135.032	galvanized steel	32	0.34
0423135.132	stainless steel		
0423135.072	galvanized steel	72	0.38
0423135.172	stainless steel		



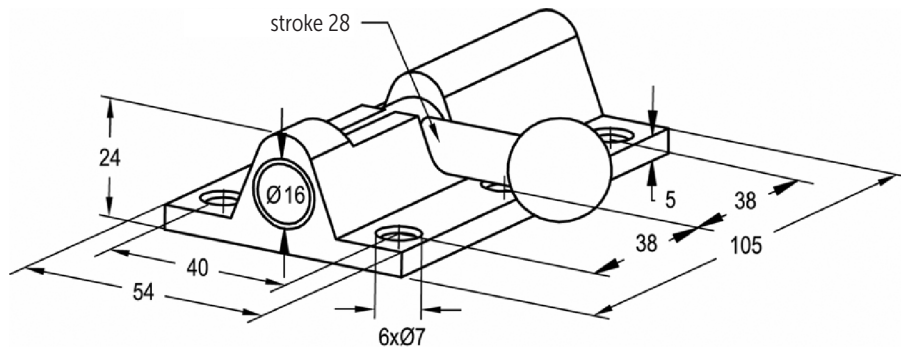

TT-number	Name	Stroke	Material	Weight
0423137.100	Plug with spring	20 mm	galvanized steel	0.38 kg/pc

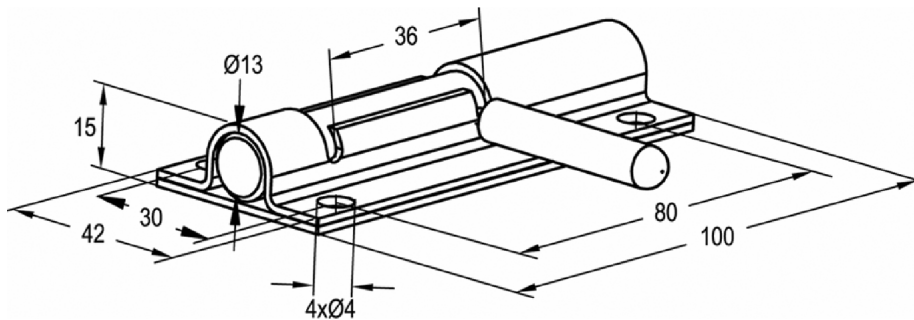

TT-number	Name	Stroke	Material	Weight
0423138.000	Plug inflexible	40 mm	galvanized steel	0.23 kg/pc





# ACCESSORIES - LOCKING CABLES

0423300.000



0423301.000



0423303.000



0423304.000



0423305.000

0423306.000



TT-number	Name	Length total	chain diameter mm	end cap 1 mm	end cap 2 mm	Material	Weight kg/pc
0423300.000	Cable diameter 6 mm with plate	250 mm		S - hook $\varnothing$ 3,5	plate / $\varnothing$ 10	plastic/galvanized	0.02
0423301.000	Cable diameter 6 mm with hook	250 mm		S - hook $\varnothing$ 3,5	hook $\varnothing$ 2,5	plastic/galvanized	0.02
0423303.000	Chain with hook	250 mm	2	S - hook $\varnothing$ 3	hook $\varnothing$ 3	galvanized steel	0.02
0423304.000	Chain with ring and carabiner	300 mm	2.3	$\varnothing$ 2,5 / $\varnothing$ 25	carabiner	Yellow galvanized	0.02
0423305.000	Chain with a splint plate	250 mm	1.8	S - hook $\varnothing$ 3	plate / $\varnothing$ 10	galvanized steel	0.02
0423306.000	Chain with a plate	265 mm	1.9	S - hook $\varnothing$ 3,8	plate / $\varnothing$ 10	galvanized steel	0.03



# REAR FACE SPLIT DIVIDED TT

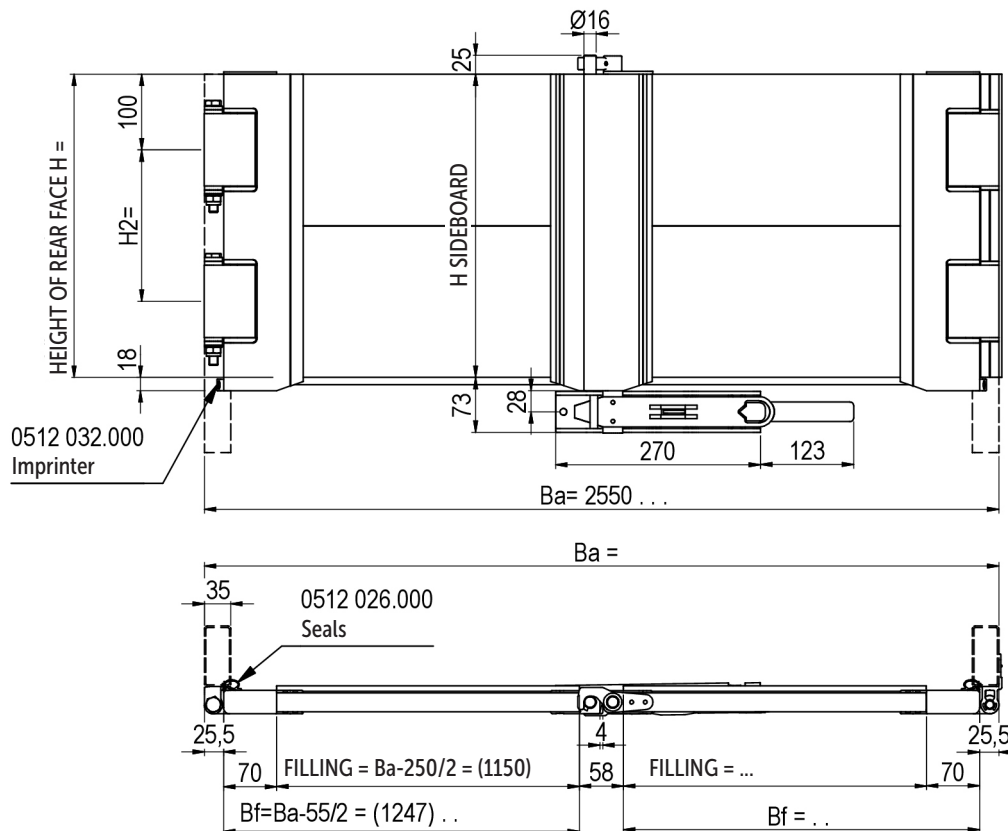

H mm	TT-number natural	TT-number anodized	Centre profile	Lower profile	Height of lower profile with seal (mm)	Weight kg/pc
406	0424340.001	0424440.001	tarpaulin		-	21
400	0424340.002	0424440.002	-	041x 004.000	200	23
400	0424340.004	0424440.004	-	041x 007.000	215	23
500	0424350.001	0424450.001	tarpaulin	041x 002.000	100	25.5
500	0424350.002	0424450.002	without pressing	041x 002.000	100	25.5
600	0424360.001	0424460.001	tarpaulin	041x 004.000	200	28
600	0424360.002	0424460.002	tarpaulin	041x 007.000	215	28
600	0424360.003	0424460.003	without pressing	041x 004.000	200	28
600	0424360.004	0424460.004	without pressing	041x 007.000	215	28
800	0424380.001	0424480.001	tarpaulin	041x 004.000	200	33
800	0424380.002	0424480.002	tarpaulin	041x 007.000	215	33
800	0424380.003	0424480.003	without pressing	041x 004.000	200	33
800	0424380.004	0424480.004	without pressing	041x 007.000	215	33
1000	0424390.001	0424490.001	tarpaulin	041x 004.000	200	38
1000	0424390.002	0424490.002	tarpaulin	041x 007.000	215	38
1000	0424390.003	0424490.003	without pressing	041x 004.000	200	38
1000	0424390.004	0424490.004	without pressing	041x 007.000	215	38



## Centre set with lower latch

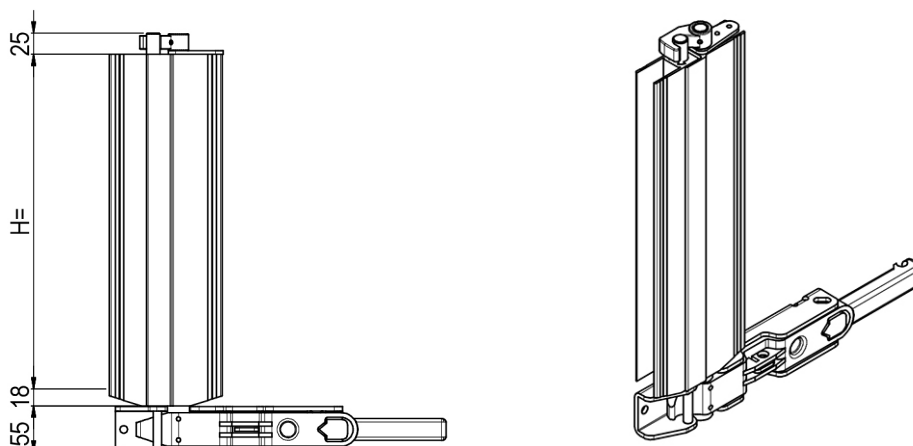

Height of face	Centre set with lower latch		
H mm	TT-number natural	TT-number anodized	Weight kg/pc
400	0424343.000	0424443.000	5.50
500	0424353.000	0424453.000	6.10
600	0424363.000	0424463.000	6.70
800	0424383.000	0424483.000	7.30
1000	0424393.000	0424493.000	8.00



# HINGES FOR REAR FACE

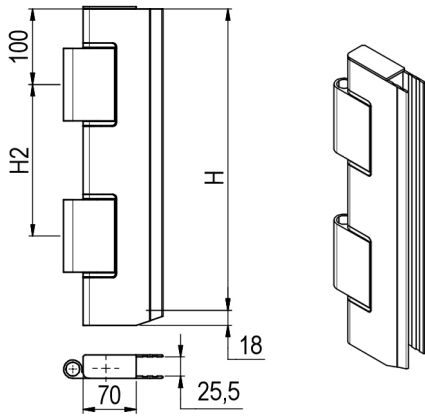

LEFT DESIGN

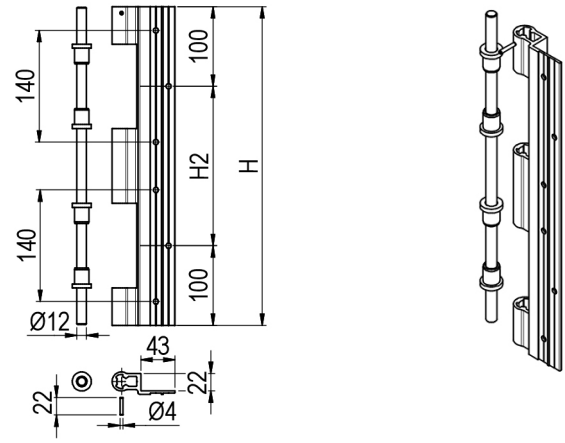

Riveting profile

Profile with hinge

Profile with hinge, Al					Riveting profile, Al		
TT-number natural	TT-number anodized	H mm	H2 mm	Weight kg/pc	TT-number natural	TT-number anodized	TT-number kg/pc
0424341.000	0424441.000	400 L	200	1.35	0424344.000	0424444.000	0.55
0424342.000	0424442.000	400 R	200	1.35			
0424351.000	0424451.000	500 L	300	1.65	0424354.000	0424454.000	0.70
0424352.000	0424452.000	500 R	300	1.65			
0424361.000	0424461.000	600 L	400	1.95	0424364.000	0424464.000	0.83
0424362.000	0424462.000	600 R	400	1.95			
0424381.000	0424481.000	800 L	600	2.24	0424384.000	0424484.000	1.10
0424382.000	0424482.000	800 R	600	2.24			
0424391.000	0424491.000	1000 L	600	2.76	0424394.000	0424494.000	1.15
0424392.000	0424492.000	1000 R	600	2.76			

TT-number	Name	Material	Weight kg/set
0512050.000	Hitch hinge screw-in, set	galvanised steel / plastic	0.8
0512053.000	Hitch hinge welded, set	steel / plastic	0.8

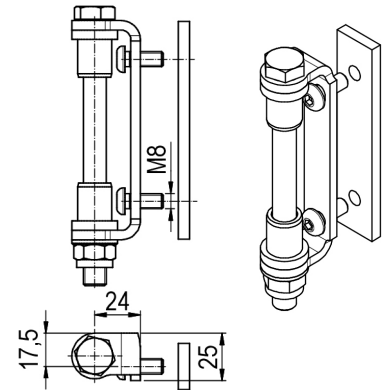

TT-number	Name	Material	Weight kg/m
0512026.000	Hinge profile seal - perimeter	rubber	0.20



TT-number	Name	Material	Weight kg/m
0512032.000	Imprinter	polyamide	0.01

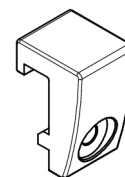

# REAR FACE DIVIDED - RECESSED LATCH TT

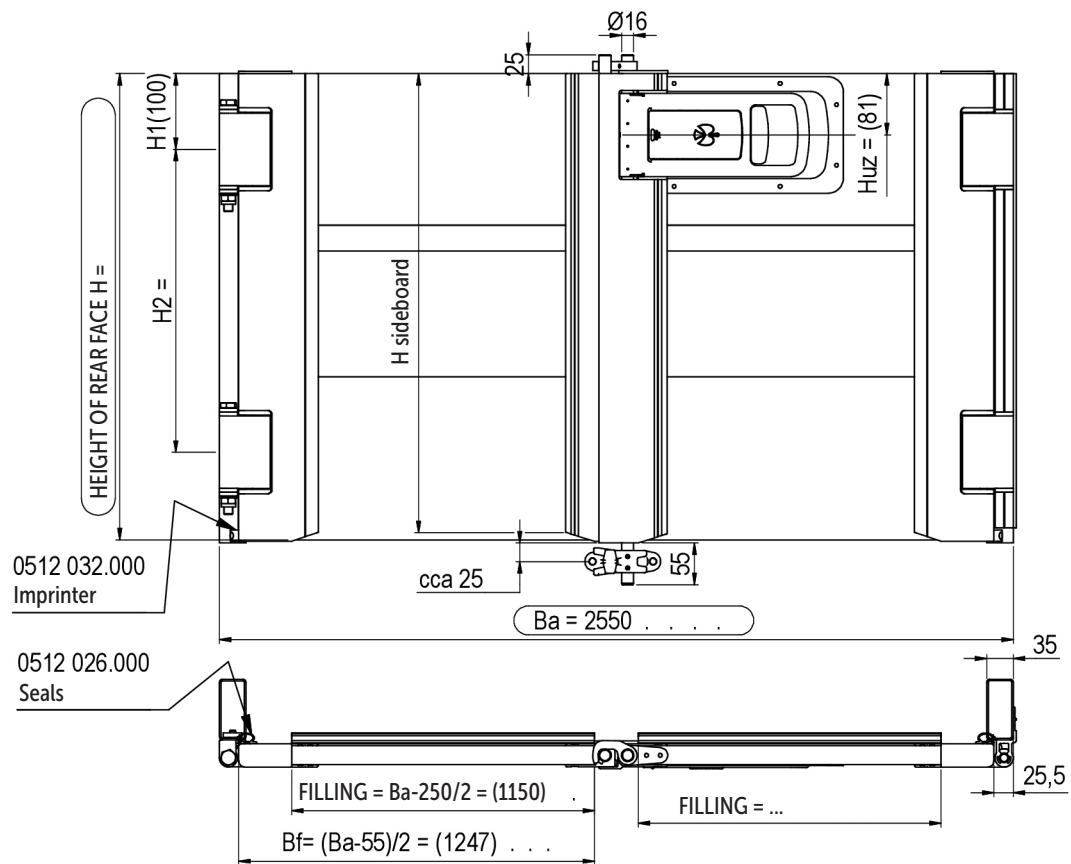

H mm	TT-number natural	TT-number anodized	Centre profile	Lower profile	Height of lower profile with seal (mm)	Weight kg/pc
406	0424340.101	0424440.101	tarpaulin	-	-	21
400	0424340.102	0424440.102	-	041x 004.000	200	23
400	0424340.104	0424440.104	-	041x 007.000	215	23
500	0424350.101	0424450.101	tarpaulin	041x 002.000	100	25.5
500	0424350.102	0424450.102	without pressing	041x 002.000	100	25.5
600	0424360.101	0424460.101	tarpaulin	041x 004.000	200	28
600	0424350.102	0424450.102	tarpaulin	041x 007.000	215	28
600	0424360.103	0424460.103	without pressing	041x 004.000	200	28
600	0424350.104	0424450.104	without pressing	041x 007.000	215	28
800	0424380.101	0424480.101	tarpaulin	041x 004.000	200	33
800	0424380.102	0424480.102	tarpaulin	041x 007.000	215	33
800	0424380.103	0424480.103	without pressing	041x 004.000	200	33
800	0424380.104	0424480.104	without pressing	041x 007.000	215	33
1000	0424390.101	0424490.101	tarpaulin	041x 004.000	200	38
1000	0424390.102	0424490.102	tarpaulin	041x 007.000	215	38
1000	0424390.103	0424490.103	without pressing	041x 004.000	200	38
1000	0424390.104	0424490.104	without pressing	041x 007.000	215	38

# LATCHES FOR THE REAR FACE

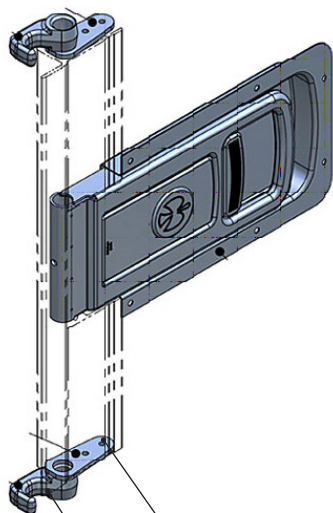

1012200.120

1012200.110

0424260.000

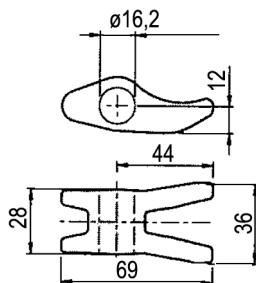
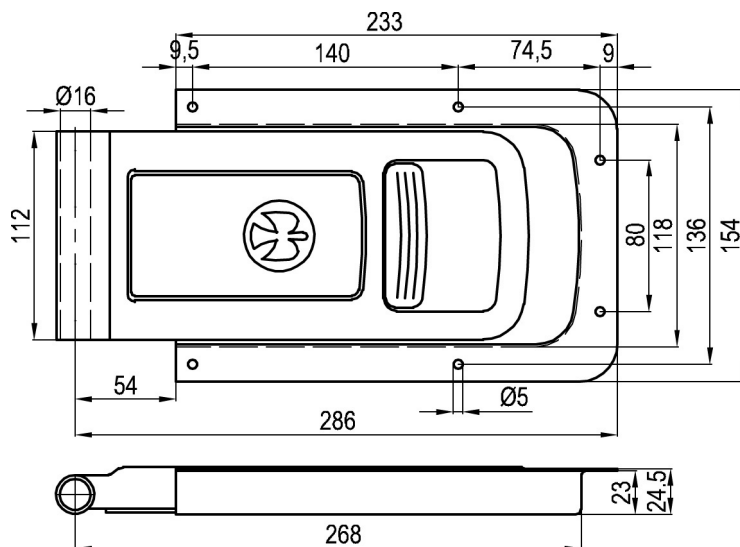

1012160.200

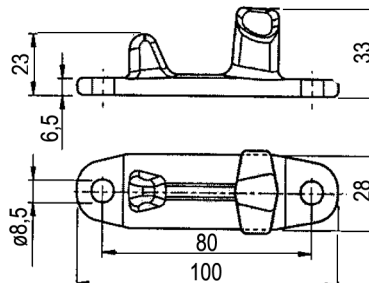

1012160.100

TT-number	Name	Material	Weight
0424260.000	Hestal 788/2 rear face latch - set	galvanized steel	1.75 kg/set
0424202.000	Interlocking insert boards.	galvanized steel	0.10 kg/pc
0424205.000	Bar diameter 16h11	galvanized steel	1.57 kg/m
1012160.100	Hook holder diameter 16	galvanized steel	0.20 kg/pc
1012160.200	Hook for diameter 16	galvanized steel	0.10 kg/pc

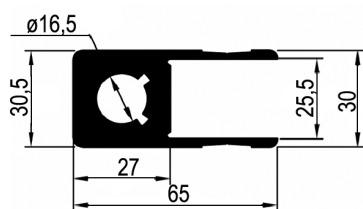

0424021.000

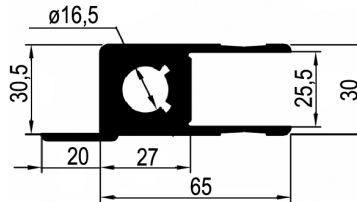

0424022.000

TT-number natural	TT-number anodized	Name	Material	Weight kg/m
0424021.000	0424921.000	Edging profile U	Al	2
0424022.000	0424922.000	Edging profile h	Al	2.25

# PROFILE FOR AL FLATBED AND PARTS FOR CONSTRUCTION OF SUBFRAME AND AL FLOOR

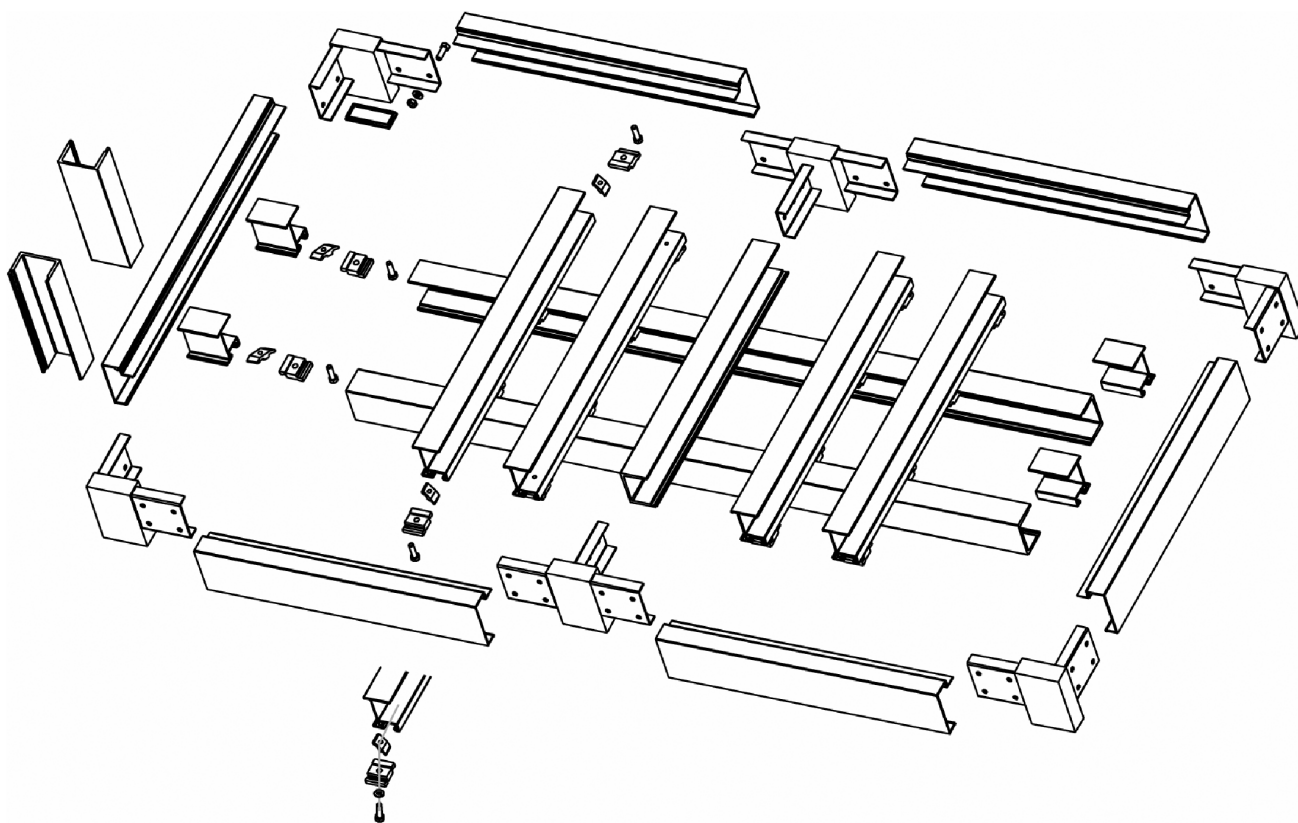
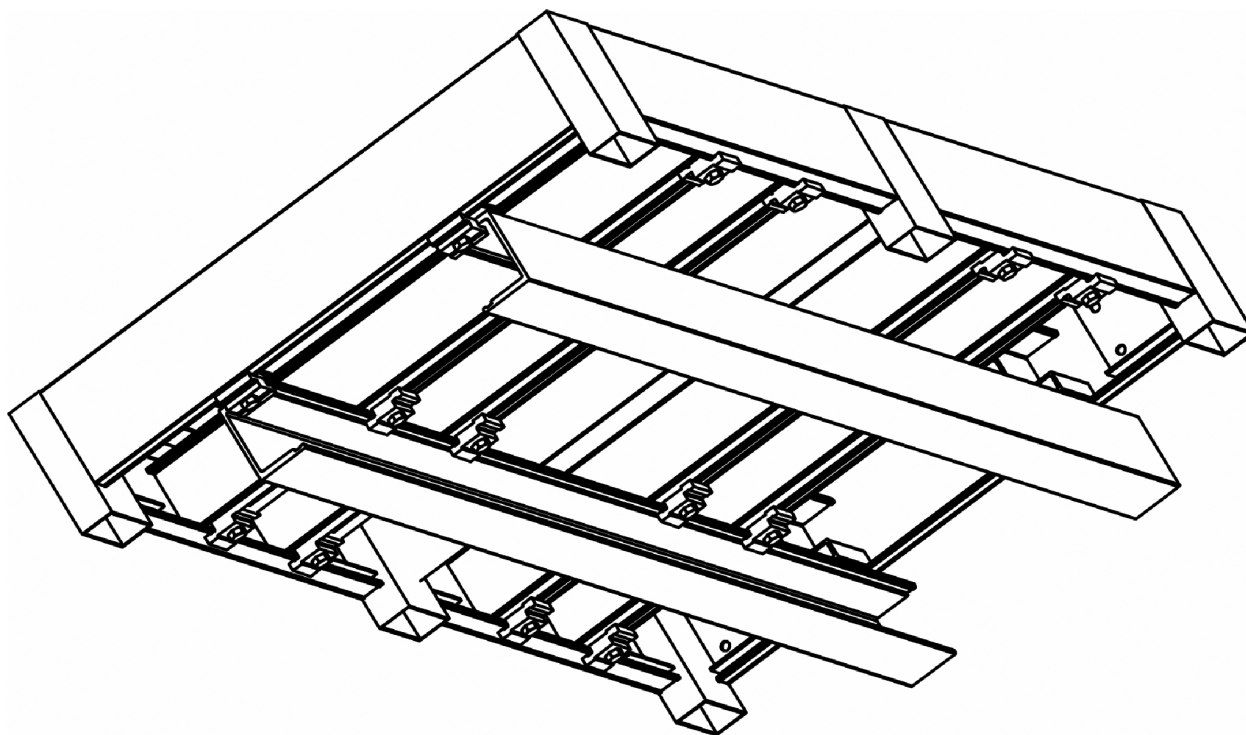

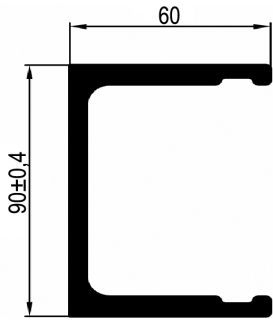

0431001.000  
0432001.000

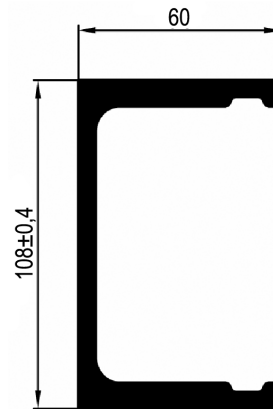

0431005.000  
0432005.000

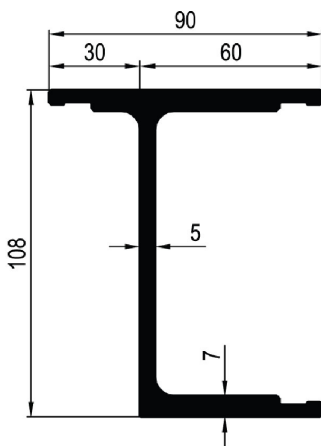

0431010.000

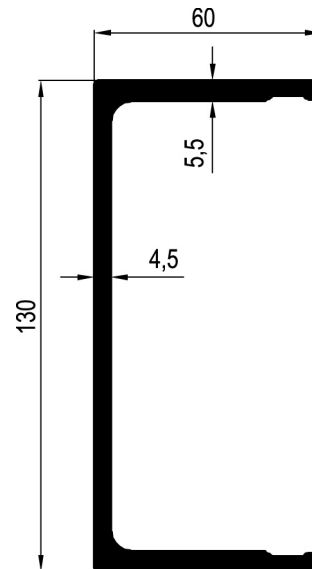

0431012.000

TT-number	Name	Surface	Material	Weight
0431001.000	Auxiliary profile 90 mm	natural	AlMgSi 0.7	3.13 kg/m
0432001.000	Auxiliary profile 90 mm	anodized		
0431005.000	Auxiliary profile 108 mm	natural	AlMgSi 0.7	3.37 kg/m
0432005.000	Auxiliary profile 108 mm	anodized		
0431010.000	Auxiliary profile 108 mm	natural	AlMgSi 0.7	3.88 kg/m
0431012.000	Auxiliary profile 130 mm	natural	AlMgSi 0.7	3.20 kg/m
0432012.000	Auxiliary profile 130 mm	anodized	AlMgSi 0.7	3.20 kg/m





# PROFILES FOR AL FLATBED AND PARTS FOR SUBFRAME CONSTRUCTION

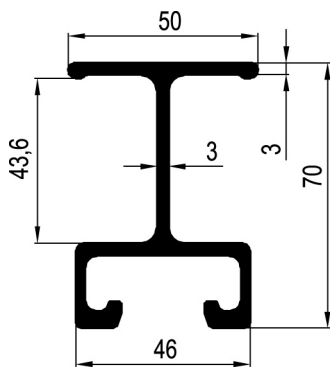

0431015.000  
0432015.000

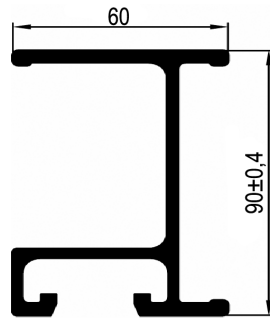

0431002.000  
0432002.000

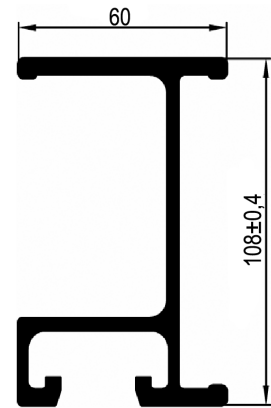

0431006.000

TT-number	Name	Surface	Material	Weight
0431015.000	Cross profile 70 mm	natural	AlMgSi 0.7	1.73 kg/m
0432015.000	Cross profile 70 mm	anodized	AlMgSi 0.7	1.73 kg/m
0431002.000	Cross profile 90 mm	natural	AlMgSi 0.7	2.29 kg/m
0432002.000	Cross profile 90 mm	anodized		
0431006.000	Cross profile 108 mm	natural	AlMgSi 0.7	2.43 kg/m
0432006.000	Cross profile 108 mm	anodized		

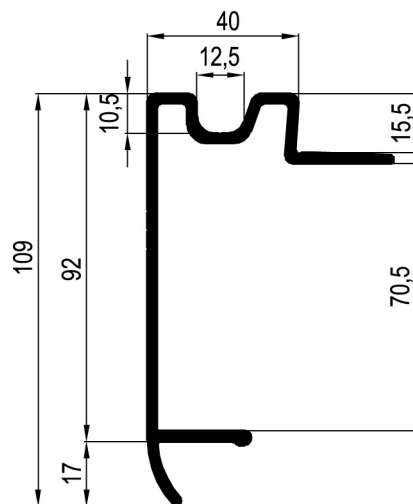

TT-number	Name	Surface	Material	Weight
0431016.000	Frame profile with groove 70 mm	natural	AlMgSi 0.7	1.64 kg/m
0432016.000	Frame profile with groove 70 mm	anodized		



# PROFILES FOR AL FLATBED AND PARTS FOR SUBFRAME CONSTRUCTION

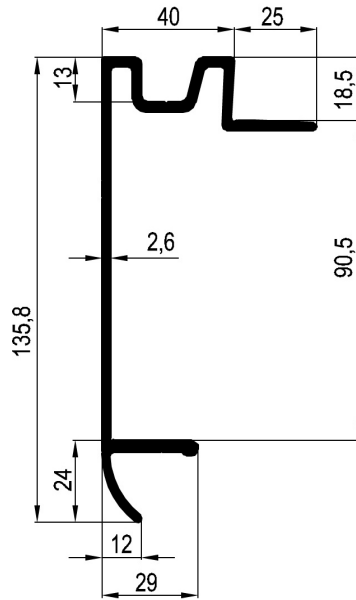

**0431014.000**  
**0432014.000**

TT-number	Name	Surface	Material	Weight
<b>0431014.000</b>	Frame profile with groove 90 mm	natural	AlMgSi 0.7	1.97 kg/m
<b>0432014.000</b>	Frame profile with groove 90 mm	anodized		

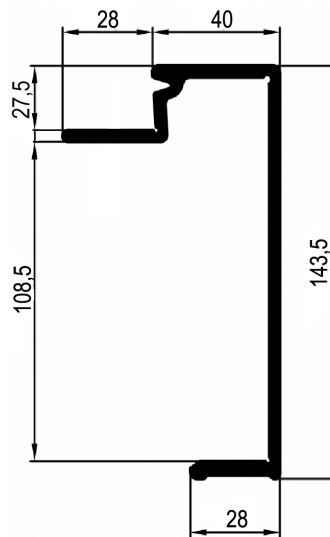

**0431007.000**  
**0432007.000**

TT-number	Name	Surface	Material	Weight
<b>0431007.000</b>	Perimeter frame profile 108 mm	natural	AlMgSi 0.7	2.3 kg/m
<b>0432007.000</b>	Perimeter frame profile 108 mm	anodized		

# PROFILES FOR AL FLATBED AND FLOOR

Floor profile 200 / 30 mm			
TT-number	Surface	Material	Weight
0431201.000	natural	AlMgSi0,5	3.05 kg/m

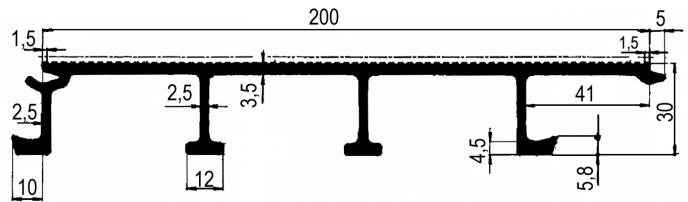

Perimeter frame profile			
TT-number	Surface	Material	Weight
0431204.000	natural	AlMgSi 0.7	3.83 kg/m

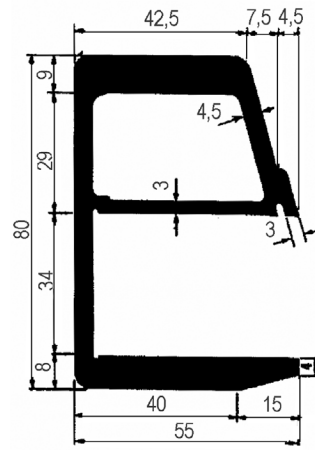

Perimeter frame profile for floor 30 mm			
TT-number	Surface	Material	Weight
0431206.000	natural	Al	1.9 kg/m

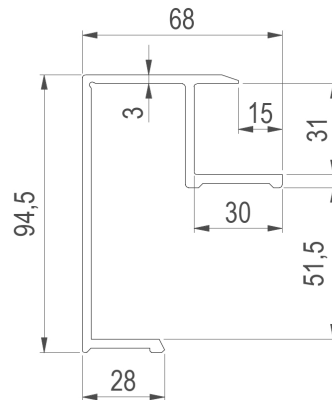

# PARTS FOR AL SUBFRAME

Front and rear corners 80 x 40 mm are pre-drilled for Al pillars 80 x 35 mm  
(0354310.100 and 0354320.100)

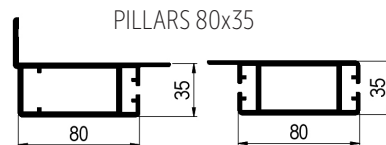
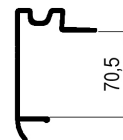
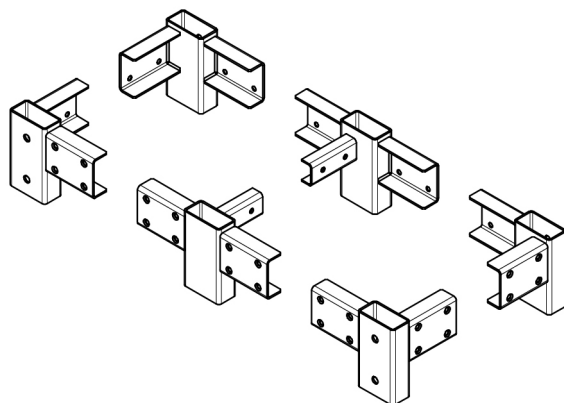

0354320.x00

0354310.x00

TT-number	Name	Surface	Weight kg/pc
0433270.000	Corner FR (RL) 80 x 40 / 70, complete, pre-drilled	galvanized	1.6
0433271.000	Corner FL (RR) 80 x 40 / 70, complete, pre-drilled	galvanized	1.6
0433274.000	Centre piece R 80 x 40 / 70, complete, undrilled	galvanized	1.8
0433275.000	Centre piece L 80 x 40 / 70, complete, undrilled	galvanized	1.8
0433079.000	Centre reinforcement for frame 70 mm, 800 mm, complete	galvanized	3.0

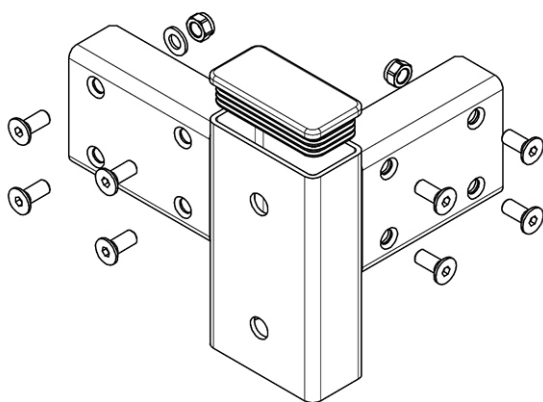

0433270.000

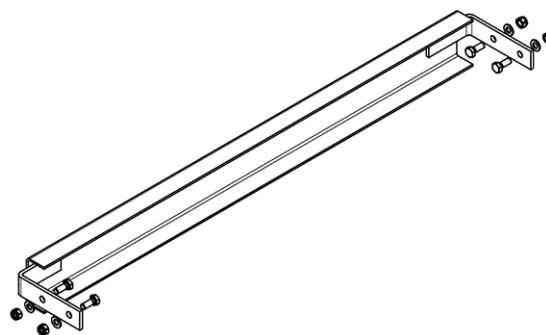

0433079.000

Corner FR (FL) / middle - set includes:				
TT-number	Name	Quantity	Surface / material	Weight kg/pc
according to the corner type	Corner FR (FL) / central	1	galvanized	according to the corner type
1904108.020	Screw M8 x 20, recessed head, 8.8	8 / 8	galvanized	0.01
1901108.020	Screw M8 x 20, hexagonal head 8.8	- / 2	galvanized	0.01
1942108.000	Nut M8 self-locking	8 / 10	galvanized	0.01
1961108.000	Washer 8.4	8 / 10	galvanized	0.01
0433009.000	Blanking plug 100 x 40 mm	1	plastic	0.05
0433010.000	Blanking plug 120 x 40 mm			



# PARTS FOR AL SUBFRAME

Front corners 80 x 40 mm and rear corners 120 x 40 mm are pre-drilled for Al pillars light (0354200.xxx and 0354220.xxx)

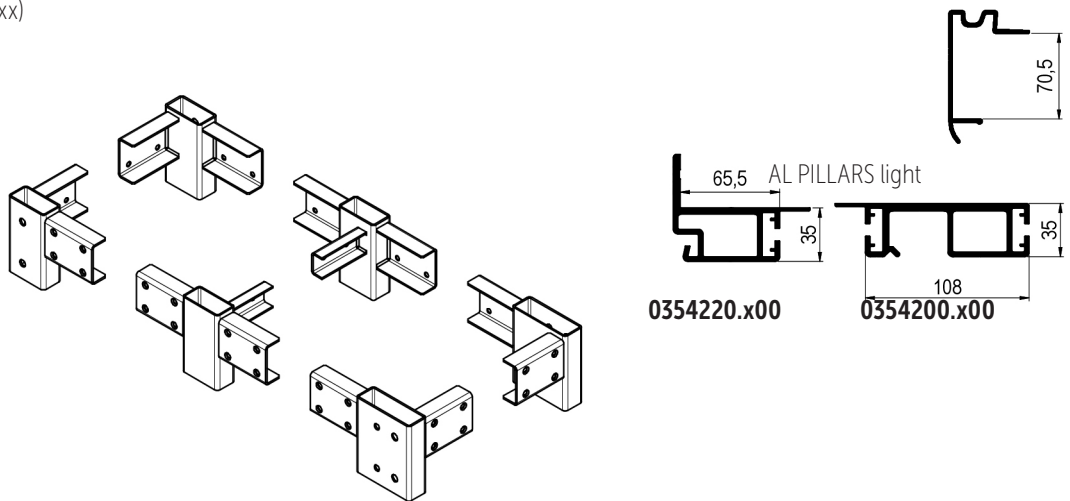

TT-number	Name	Surface	Weight kg/pc
0433277.000	Corner FR (RL) 80 x 40 / 70, complete, pre-drilled	galvanized	1.6
0433278.000	Corner FL (RR) 80 x 40 / 70, complete, pre-drilled	galvanized	1.6
0433274.000	Centre piece R 80 x 40 / 70, complete, undrilled	galvanized	1.8
0433275.000	Centre piece L 80 x 40 / 70, complete, undrilled	galvanized	1.8
0433073.000	Corner RL 120 x 40 / 70 mm pre-drilled, galvanized, complete, Al column light	galvanized	1.9
0433072.000	Corner RR 120 x 40 / 70 mm pre-drilled, galvanized, complete, Al column light	galvanized	1.9
0433079.000	Centre reinforcement for frame 70 mm, 800 mm, complete	galvanized	3.0

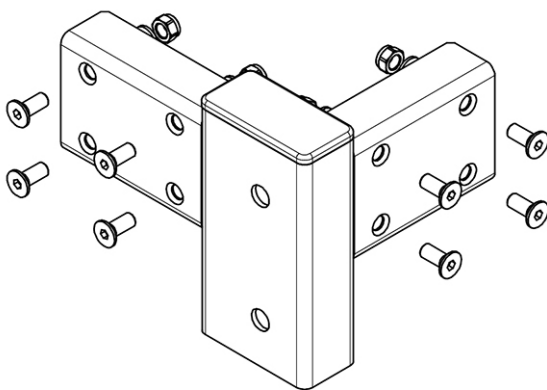

0433277.000

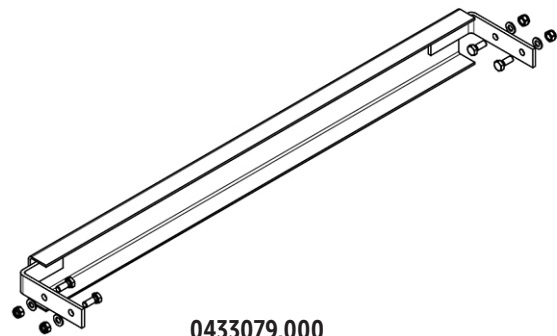

0433079.000

Corner FR (FL) / middle - set includes:				
TT-number	Name	Quantity	Surface / material	Weight kg/pc
according to the corner type	Corner FR (FL) / central	1	galvanized	according to the corner type
1904108.020	Screw M8 x 20, recessed head, 8.8	8 / 8	galvanized	0.01
1901108.020	Screw M8 x 20, hexagonal head, 8.8	- / 2	galvanized	0.01
1942108.000	Nut M8 self-locking	8 / 10	galvanized	0.01
1961108.000	Washer 8.4	8 / 10	galvanized	0.01
0433009.000	Blanking plug 100 x 40 mm	1	plastic	0.05
0433010.000	Blanking plug 120 x 40 mm			

# PARTS FOR AL SUBFRAME

Corners undrilled for 70 mm frame, pillars according to choice

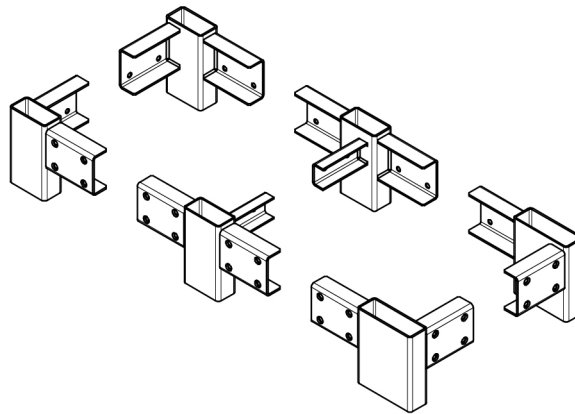
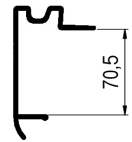

TT-number	Name	Surface	Weight kg/pc
0433280.000	Corner FR (RL) 80 x 40 / 70, complete, undrilled	galvanized	1.6
0433281.000	Corner FL (RR) 80 x 40 / 70, complete, undrilled	galvanized	1.6
0433274.000	Centre piece R 80 x 40 / 70, complete, undrilled	galvanized	1.8
0433275.000	Centre piece L 80 x 40 / 70, complete, undrilled	galvanized	1.8
0433282.000	Corner FR 120 x 40 / 70, complete, undrilled	galvanized	1.9
0433283.000	Corner RL 120 x 40 / 70, completely undrilled	galvanized	1.9
0433079.000	Centre reinforcement for frame 70 mm, 800 mm, complete	galvanized	3.0

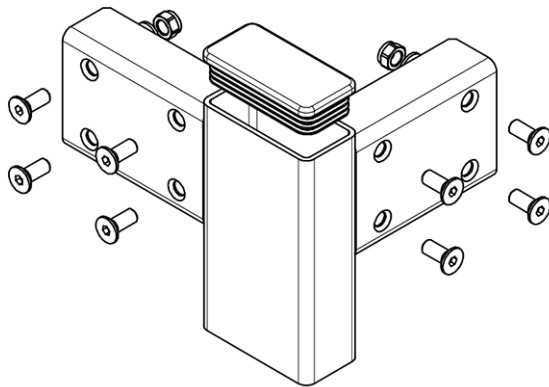

0433280.000

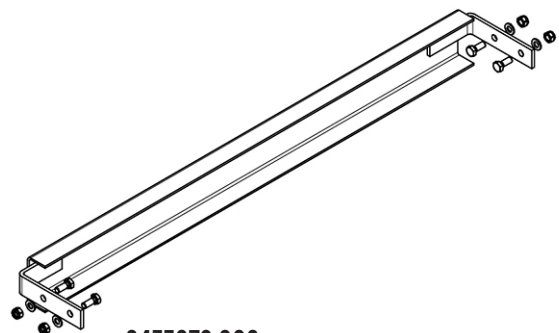

0433079.000

Centre reinforcement for frame 70 mm, 800 mm, complete

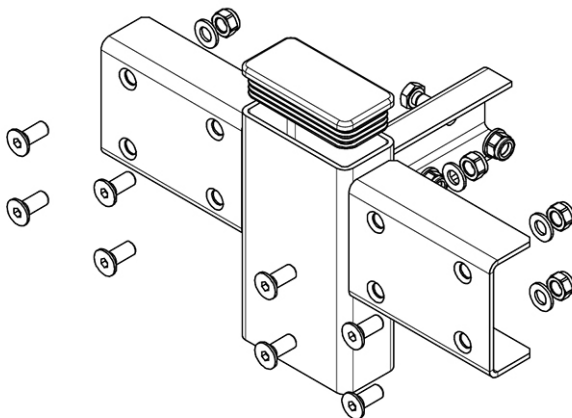

0433275.000

# PARTS FOR AL SUBFRAME

Designed for 70 and 90 mm frame, for Al light pillars

## 0433077.100

Part for MINI gearbox RL, set  
Material: galvanized steel

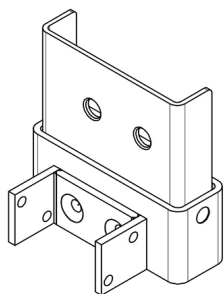

## 0433077.200

Part for MINI gearbox RR, set  
Material: galvanized steel

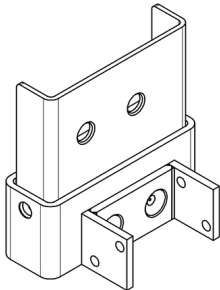

## 0433077.300

MINI gearbox holder  
Material: galvanized steel

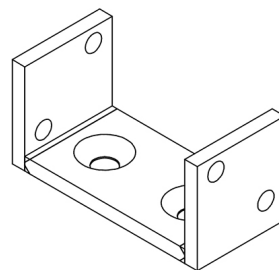

## 0433078.100

Part for ratchet PWP RL, set  
Material: galvanized steel

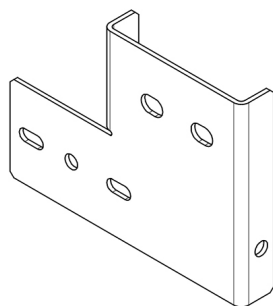

## 0433078.200

Part for ratchet PWP RR, set  
Material: galvanized steel

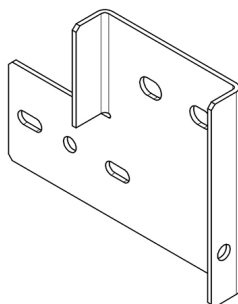

## 0433078.300

Spacer plate for PWP ratchet  
Material: galvanized steel

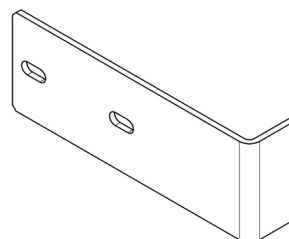

## 0433068.100

Ratchet holder PWP - bent, RL  
Material: galvanized steel

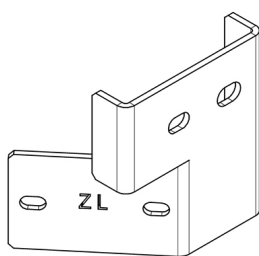

## 0433068.200

Ratchet holder PWP - bent, RR  
Material: galvanized steel

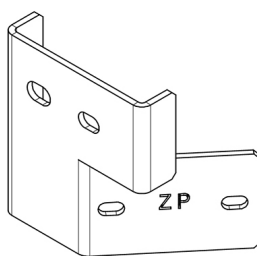

# PARTS FOR AL SUBFRAME

Corners undrilled for 90 mm frame, pillars according to choice

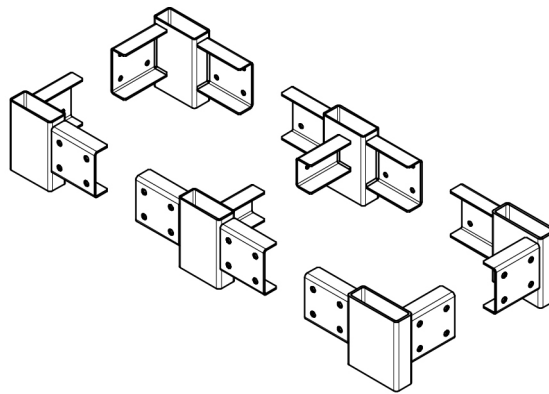
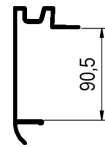

TT-number	Name	Surface	Weight kg/pc
0433140.000	Corner FR (RL) 100 x 40 / 90, complete	galvanized	1.8
0433141.000	Corner FL (RR) 100 x 40 / 90, complete	galvanized	1.8
0433142.000	Centre piece R 100 x 40 / 90, complete	galvanized	2.2
0433143.000	Centre piece L 100 x 40 / 90, complete	galvanized	2.2
0433150.000	Corner FR (RL) 120 x 40 / 90, complete	galvanized	2.3
0433151.000	Corner FL (RR) 120 x 40 / 90, complete	galvanized	2.3
0433149.000	Centre reinforcement for frame 90 - 18 mm with groove, L = 800 mm, complete	galvanized	3.4

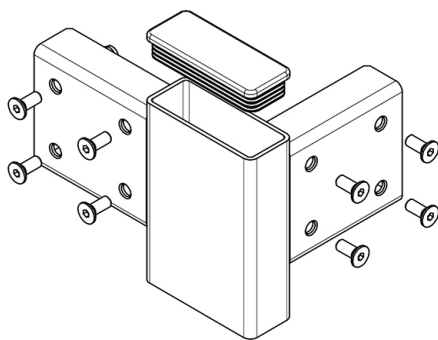

0433140.000

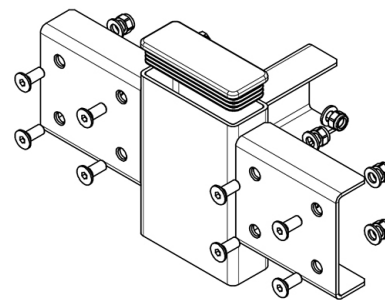

0433143.000

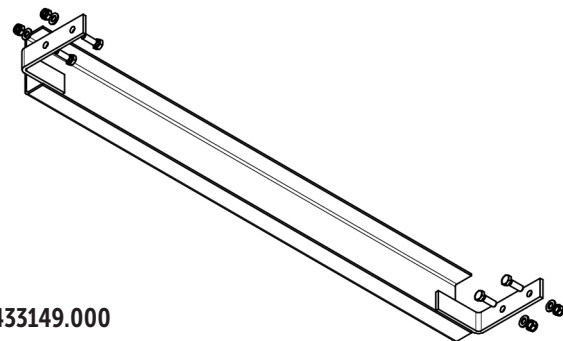

0433149.000





# PARTS FOR AL SUBFRAME

Corners undrilled for MIDI pillars, CS subframe and 90 mm frame

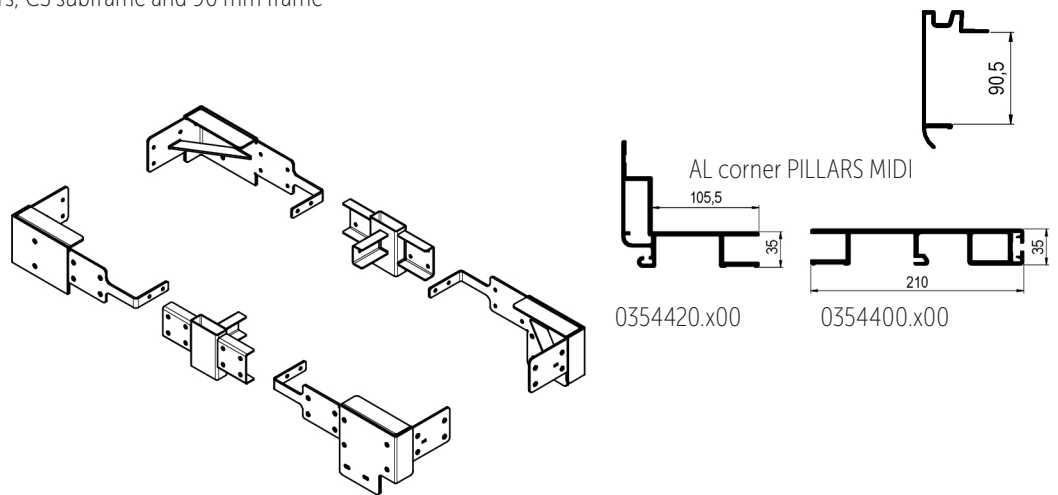

TT-number	Name	Surface	Weight kg/pc
0433094.100	Corner RL for frame 90-18, for MIDI sl, complete	galvanized	5.3
0433094.200	Corner FL for frame 90-18, for MIDI sl, complete	galvanized	4.6
0433094.300	Corner RR for frame 90-18, for MIDI sl, complete	galvanized	5.3
0433094.400	Corner FR for frame 90-18, for MIDI sl, complete	galvanized	4.6
0433142.000	Centre piece R 100 x 40 / 90, complete	galvanized	2.2
0433143.000	Centre piece L 100 x 40 / 90, complete	galvanized	2.2
0433149.000	Centre reinforcement for frame 90 - 18 mm with groove, L = 800 mm, complete	galvanized	3.4

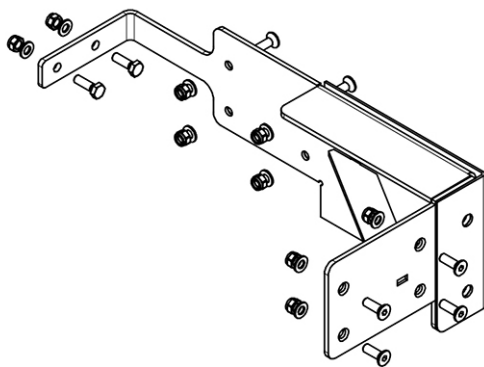

0433094.200

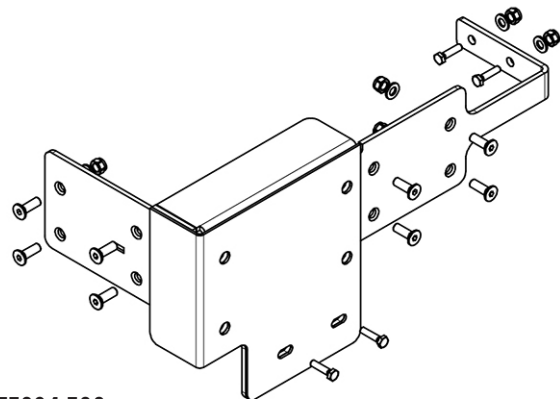

0433094.300

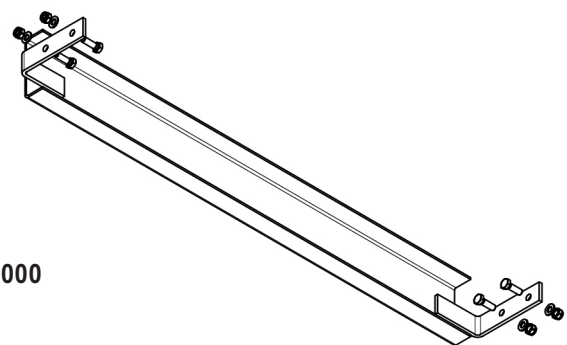

0433149.000

# PARTS FOR AL SUBFRAME

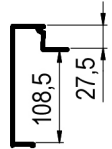
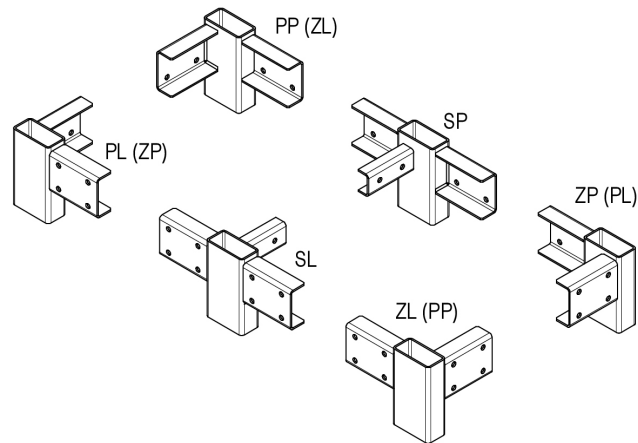

TT-number	Name	Surface	Weight kg/pc
0433060.000	Corner FR (RL) 120 x 40/ 108, complete	galvanized	4.40
0433061.000	Corner FL (RR) 120 x 40/ 108, complete	galvanized	4.40
0433062.000	Corner middle R 120 x 40 / 108, complete	galvanized	1.71
0433063.000	Corner middle L 120 x 40 / 108, complete	galvanized	1.71

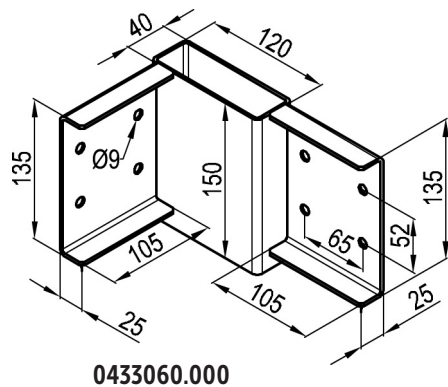

0433060.000

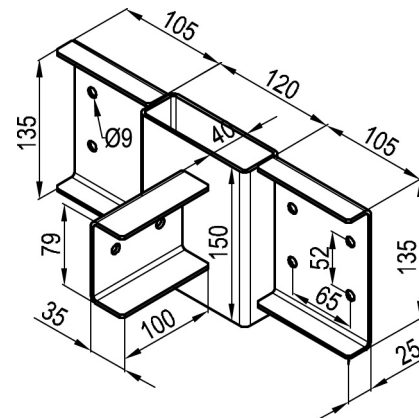

0433062.000



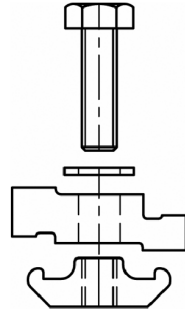

**0433030.000**  
**0433030.100**

TT-number	Name	Quantity	Surface / material	Weight kg/pc
<b>0433030.000</b>	Clamp Palcom L = 44 mm - complete set includes:	set		0.22
<b>0433031.000</b>	Threaded part M10/20 mm R	1	Al	0.02
<b>0433032.000</b>	10.5/44 mm part with screw and washer	1	Al/Zn	0.11
<b>0433030.100</b>	Clamp Palcom L = 100 mm - complete set includes:	set		
<b>0433031.000</b>	Threaded part M10/20 mm	1	Al	0.02
<b>0433032.100</b>	10.5/100 mm part with screw and washer	1	Al/Zn	
<b>0433033.000</b>	Threaded part + screw + washer R		Al/Zn	0.09

TT-number	Name	Weight kg/pc
<b>0433035.100</b>	High strength adhesive for securing PERMABOND screws	0.01

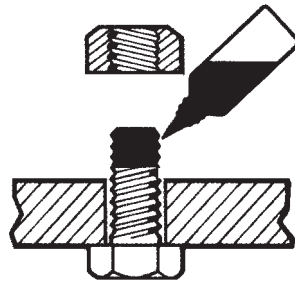

**0433028.000**



**0433029.000**

TT-number	Name	Weight kg/pc
<b>0433028.000</b>	Profile of Palcom upper	1.10
<b>0433029.000</b>	Profile of Palcom lower	1.75



0441101.000

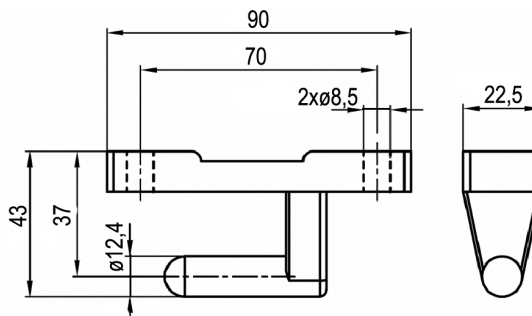
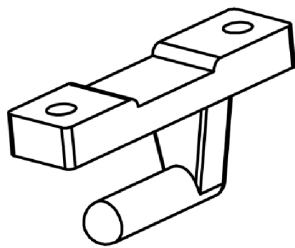

0441102.000

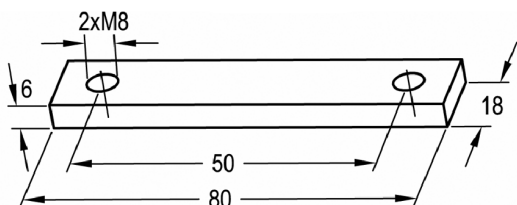
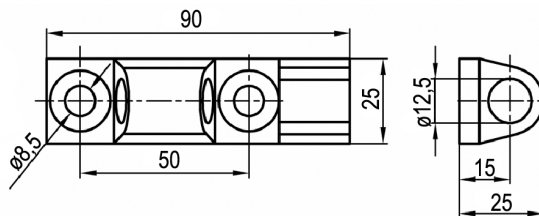
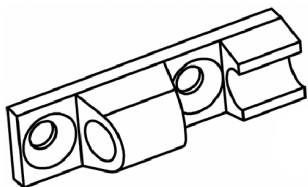

0441103.000

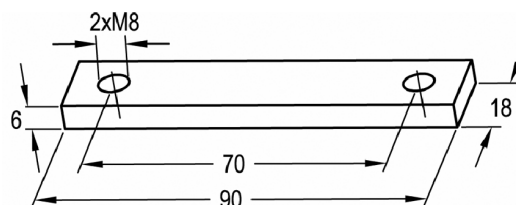

0441104.000

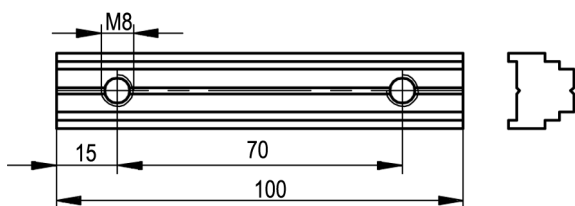

0441104.100



0441010.000

TT-number	Name	Quantity	Surface / material	Weight kg/pc
0441111.001	Hinge TIR complete for profiles with flag 0411001 / 003	set	galvanized	0.58
0441111.002	Hinge TIR complete for profiles with 0411002 / 004 seals	set	galvanized	0.58
0441111.003	Hinge TIR complete for profile 400 mm 0411101	set	galvanized	0.58
0441111.004	Hinge TIR complete for profile 406 mm 0411104104	set	galvanized	0.58
<b>The set consists of:</b>				
0441101.000	TIR hinge pin	1	galvanized	0.24
0441102.000	TIR hitch hinge	1	galvanized	0.19
0441103.000	Threaded plate 80 / 50 for hitch	1	galvanized	0.06
0441104.000	Threaded plate 90 / 70 for pin	1	galvanized	0.07
0441104.100	Threaded plate Al 100 / 70 for pin	1	Al	0.05
1904108.020	Screw M8 x 20 for hitch	2	galvanized	0.01
1904108.030	Screw M8 x 30 for profile 0411104	2	galvanized	0.01
1904108.025	Screw M8 x 25 for profile with flag	2	galvanized	0.01
1904108.035	Screw M8 x 35 for profile with seal	2	galvanized	0.01

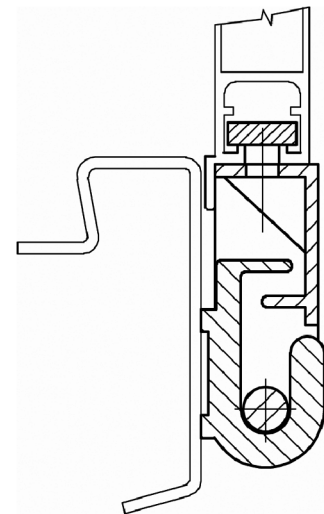
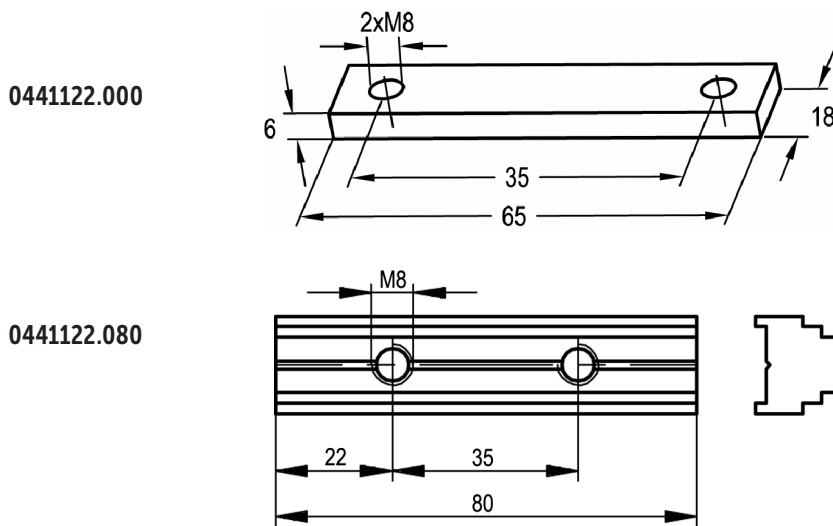
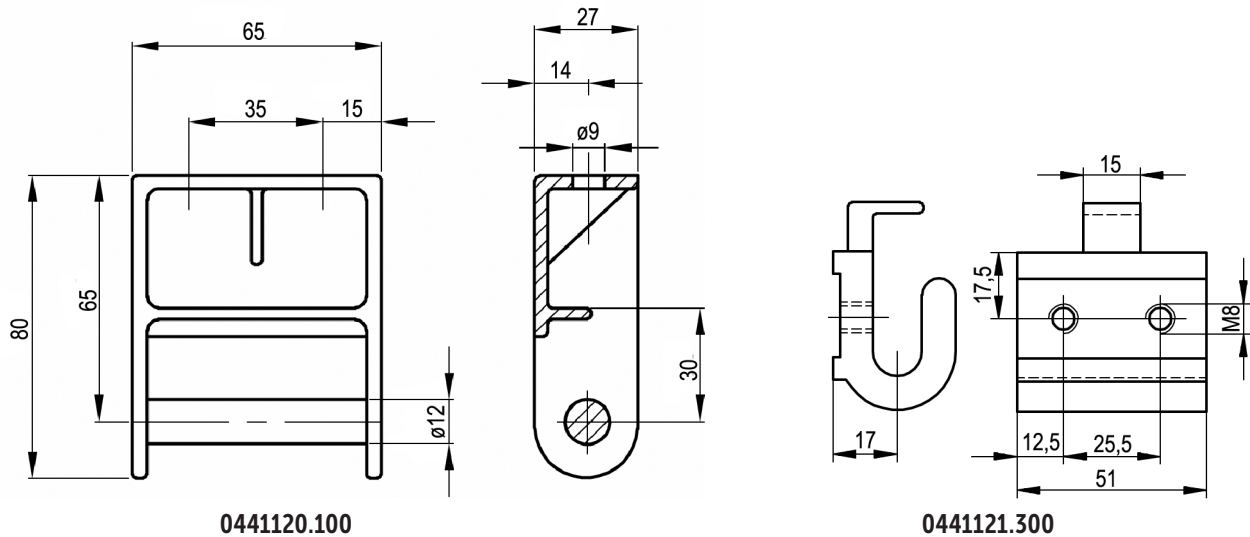

TT-number	Name	Quantity	Surface / material	Weight kg/pc
0441119.100	Box hinge - galvanized / hitch galvanized	set	galvanized	
0441119.200	Box hinge - galvanized / hitch steel natural	set	galvanized	
0441119.300	Box hinge - zinc plated / hitch threaded galvanized	set	galvanized	
<b>The set consists of:</b>				
0441120.200	Hinge box	1	galvanized	0.30
0441120.100	Hinge box	1	steel	0.30
0441121.100	Sideboard hitch hinge	1	steel	0.30
0441121.200	Sideboard hitch hinge	1	galvanized	0.30
0441121.300	Sideboard hitch hinge threaded	1	galvanized	0.30
0441122.000	Threaded plate 65 / 35 for hinge	1	galvanized	0.05
0441122.080	Threaded plate 80 / 35	1	Al	0.05
1903108.030	Screw M8 x 30, ISO 4762 for diameter with seal	2	galvanized	0.01
1903108.020	Screw M8 x 20, ISO 4762 for profile with flag	2	galvanized	0.01
1903108.018	Screw M8 x 18, ISO 4762 for profile 400 mm	2	galvanized	0.01
1962108.000	Flexible washer 8.2	2	galvanized	0.01

# Hestal 657 SIDEBORD HINGES

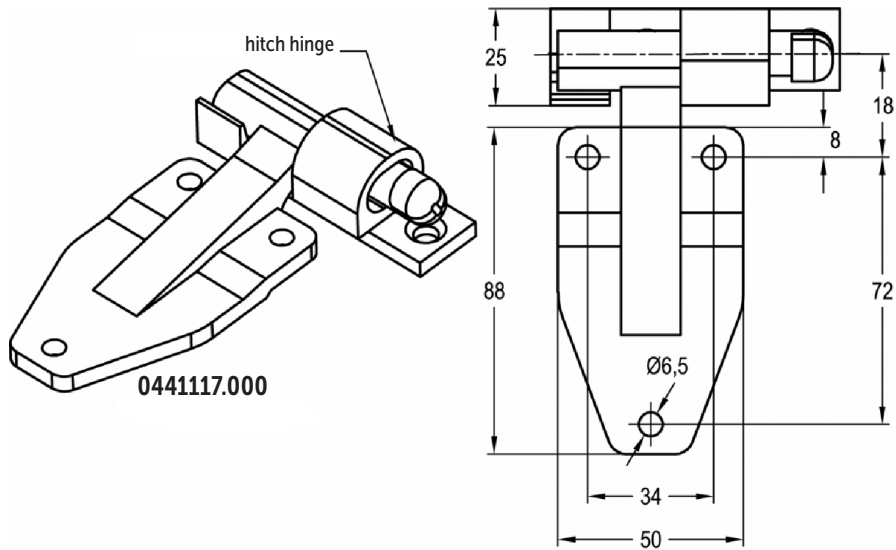
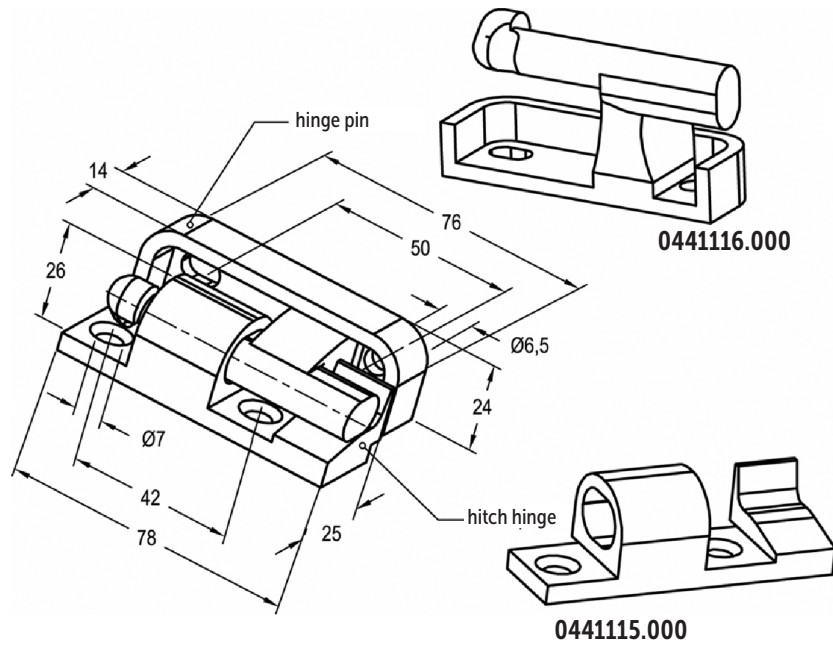

TT-number	Name	Surface / material	Weight kg/pc
0441115.000	Hitch hinge Hestal 657	galvanized	0.12
0441116.000	Hinge pin with two holes	galvanized	0.18
0441117.000	Hinge pin with three holes	galvanized	0.24

# Hestal 654.655 SIDEBORD HINGES

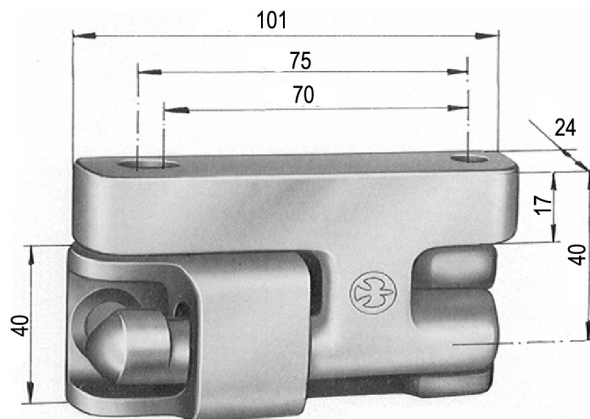

TT-number	Name	Surface / material	Weight kg/pc
0441129.000	HESTAL 6540N galvanized hinge, for profile with flag, complete	set	
0441129.002	Hinge HESTAL 6540N galvanized, for profile with seal, complete	set	
0441130.100	Hestal 654N hitch hinge	steel	0.27
0441130.200	Hestal 654N hitch hinge	galvanized	0.27
0441131.000	Hestal 654N hinge pin	galvanized	0.32
0441104.000	Threaded plate 90 / 70	galvanized	0.07
0441104.100	Threaded plate Al 100 / 70 for pin	Al	0.05
0441132.000	Threaded plate 100 / 75 / 18 / 6	galvanized	0.08
1903108.030	Screw M8 x 30 DIN 912	galvanized	0.01
1904108.020	Screw M8 x 20 DIN 7991	galvanized	0.01
1962108.000	Flexible washer	galvanized	0.01

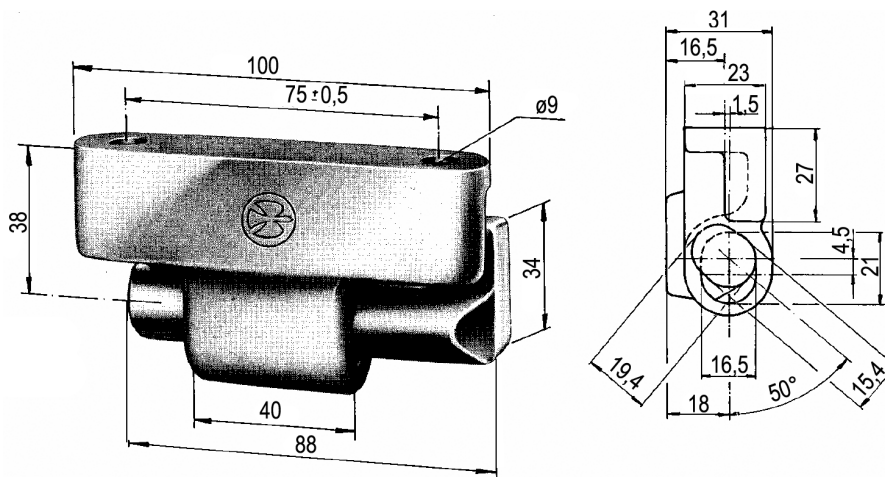

TT-number	Name	Surface / material	Weight kg/pc
0441135.000	Hinge pin right Hestal 655N	steel	0.25
0441136.000	Hinge pin left Hestal 655N	steel	0.25
0441137.000	Hestal 655N hitch hinge	galvanized	0.36
0441132.000	Threaded plate 100 / 75 / 18 / 6	galvanized	0.08
1903108.030	Screw M8 x 30 DIN 912	galvanized	0.01
1962108.000	Flexible washer	galvanized	0.01

# SIDEBORD HINGES ITAL

We recommend using these hinges with ITAL TRAILER LOCK pillars.  
See catalogue sheets 03.02.05.x

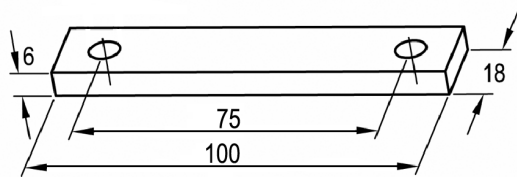
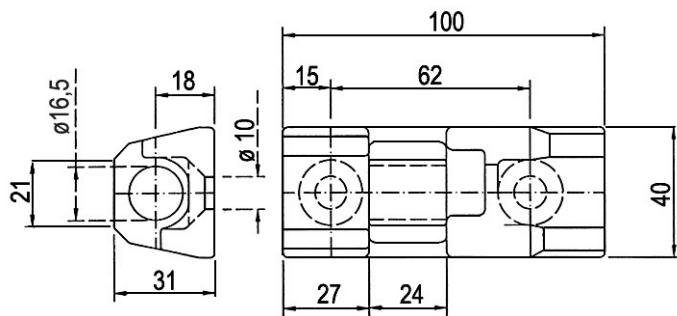
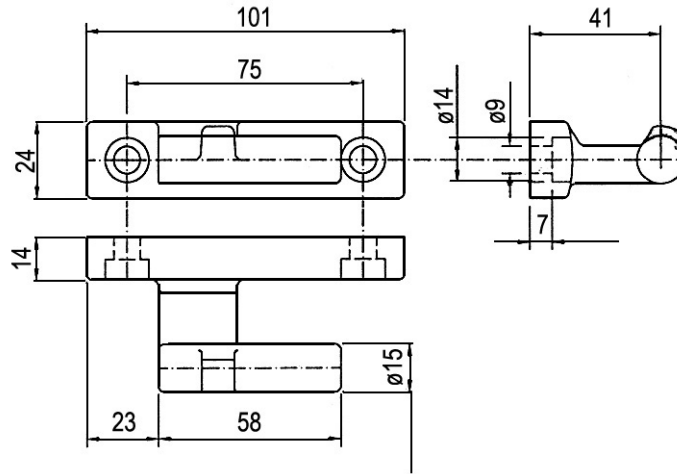

0441132.000

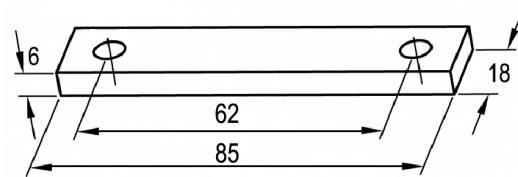

0441162.000

TT-number	Name	Quantity	Surface / material	Weight kg/pc
0441159.001	Hinge ITAL complete for profiles with flag 0411001 / 003003	set	galvanized	
0441159.002	Hinge ITAL complete for profiles with seal 0411002 / 004	set	galvanized	
0441159.003	Hinge ITAL complete for profile 400 mm 041101	set	galvanized	
<b>The set consists of:</b>				
0441160.000	Hinge pin	1	galvanized	0.32
0441161.000	Hitch hinge	1	galvanized	0.37
0441132.000	Threaded plate 100 / 75 / 18 / 6 for pin	1	galvanized	0.15
0441132.100	Threaded plate 100 / 75 2xM8 for pin	1	Al	0.05
0441162.000	Threaded plate 85 / 62 / 18 / 6 for hitch	1	galvanized	0.08
1903108.020	Screw M8 x 20 for hitch	2	galvanized	0.01
1903108.020	Screw M8 x 20, ISO 4762 for profile with flag (for pin)	2	galvanized	0.01
1903108.030	Screw M8 x 30, ISO 4762 for diameter with seal (for pin)	2	galvanized	0.01
1903108.018	Screw M8 x 18, ISO 4762 for profile 400 mm (for pin)	2	galvanized	0.01
1962108.000	Flexible washer 8.2	2	galvanized	0.01





# FRAME PROFILES FOR FLATBED - STEEL, ROLLED

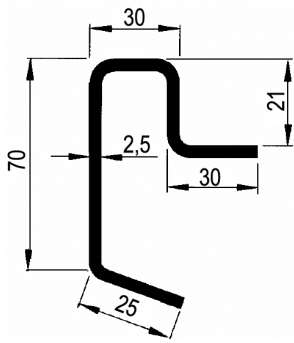

0451007.210

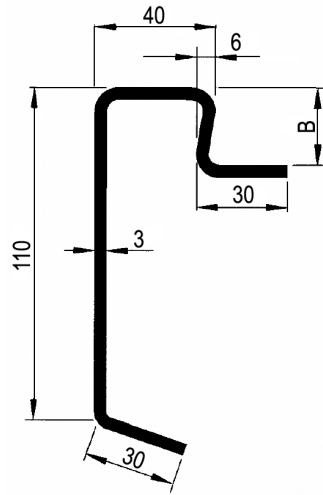

0451011.211  
0451011.271  
0451011.300

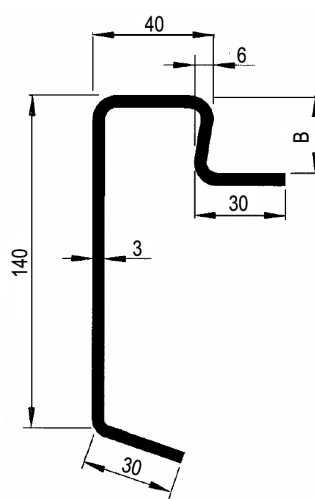

0451014.270

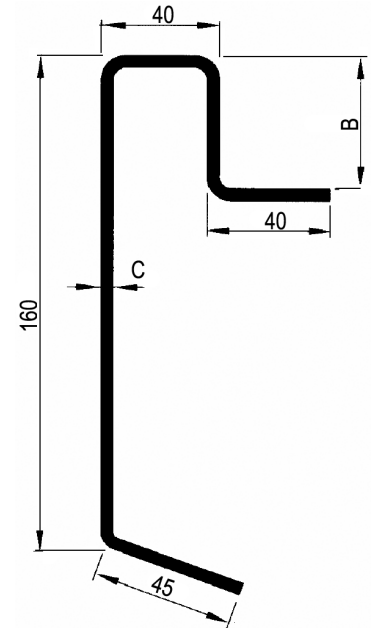

0451016.240  
0451016.274  
0451016.400  
0451016.404

Perimeter frame profiles, rolled, material 11373 (St 37-2)						
TT-number	Height of profile mm	Floor thickness B mm	Material thickness C mm	L profile mm	Wx cm <sup>3</sup>	Weight kg/m
0451007.210	70	21	2.5	6300	6.09	3.33
0451011.211	110	21	3.0	7500	15.96	5.00
0451011.271		27	3.0	7500	15.79	5.16
0451011.300		30	3.0	6300	15.74	5.25
0451014.270	140	27	3.0	7300		6.05
0451016.240	160	24	3.0	7300	33.33	7.25
0451016.274		27	4.0	7300	44.22	8.95
0451016.400		40	3.0	7300	32.63	7.60
0451016.404		40	4	7300	43.5	9.33



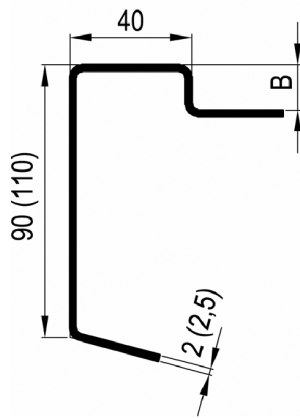

0451 109.152  
 0451 109.180  
 0451 111.150  
 0451 111.180

Perimeter frame profiles, bent, material 11373					
TT-number	Height of profile mm	Floor thickness B mm	Material thickness mm	L profile mm	Weight kg/pc
0451109.151	90	15	2.0	2500	10.90
0451109.152	90	15	2.0	2500	7.00
0451109.180	90	18	2.0	2500	7.20
0451111.150	110	15	2.5	2500	10.90
0451111.180	110	18	2.5	2500	11.20



# FRAME PROFILES FOR FLATBED - STEEL, ROLLED

Perimeter profile, frame profile with holes for anchor strips. The upper sloping surface of the frame profile has circular holes  $\varnothing 40$  mm. The distance between the holes is 300 mm.

Pillar holes for anchoring spike hooks; clamping belts.

The belts are always anchored with the sideboards open.

Once the load is secured, the sideboards can be easily closed again.

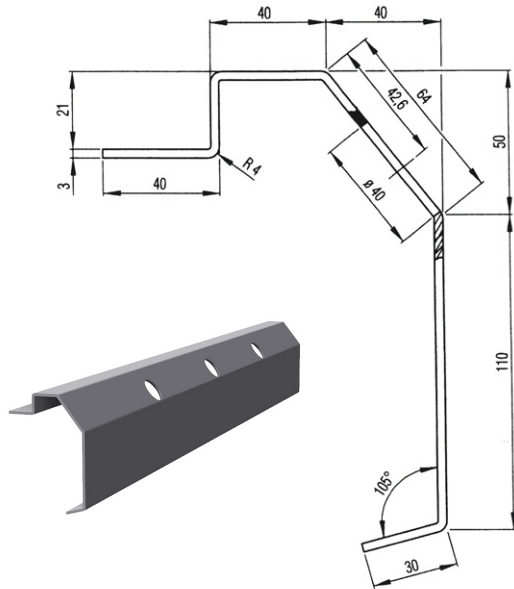

0451026.210

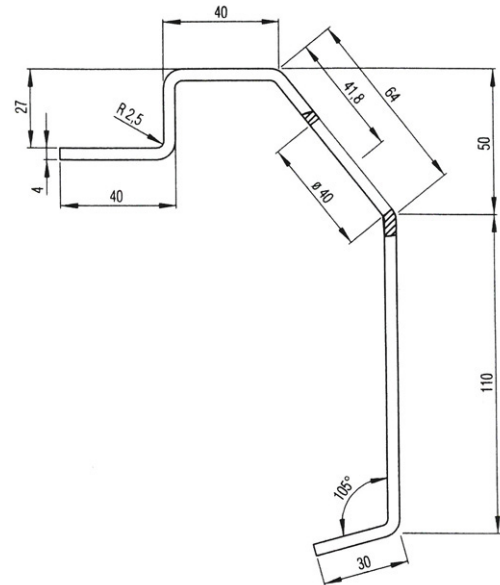

0451026.270

TT-number	Height of profile mm	Floor thickness B mm	Material thickness mm	L profile mm	$I_x$ cm <sup>4</sup>	$I_y$ cm <sup>4</sup>	$W_x$ cm <sup>3</sup>	$W_y$ cm <sup>3</sup>	Weight kg/pc
0451026.210	160	21	3.0	7500	336.19	53.7	32.27	6.32	6.83
0451026.270	160	27	4.0	7500	448.19	73.73	45.18	7.34	8.9



# FRAME PROFILES FOR FLATBED - STEEL

Perimeter profile, frame profile with holes for anchor strips.

There are 27 x 40 mm holes in the upper sloping surface of the frame profile.

The distance between the holes is 300 mm.

The belts are always anchored with the sideboards open.

Once the load is secured, the sideboards can be easily closed again.

Material: S 355 MC

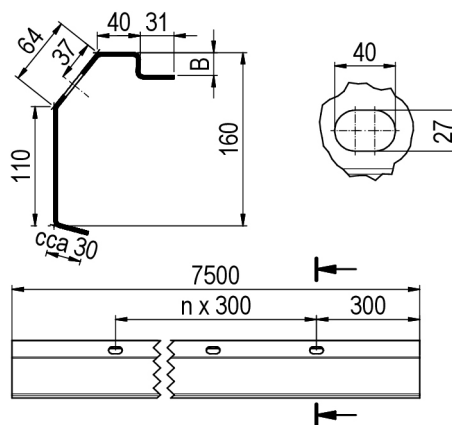
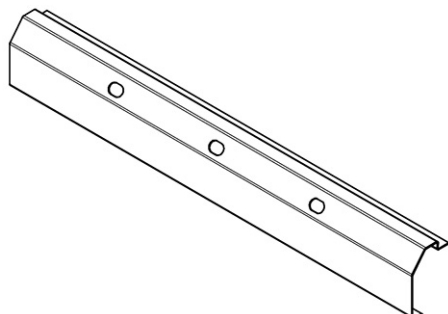

TT-number	Height of profile mm	Floor thickness B mm	Material thickness mm	L profile mm	Weight kg/m	Weight kg/pc
0451027.210	160	21	3.0	7500	6.8	51.0
0451027.270	160	27	3.0	7500	6.8	51.0

Perimeter profile, frame profile with holes for anchor shackles 0911021.000.

The distance between the holes is 500 mm.

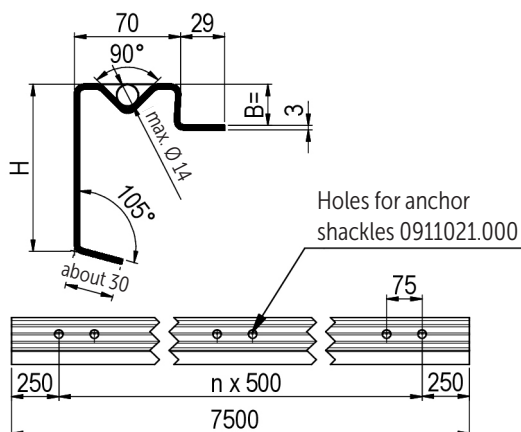
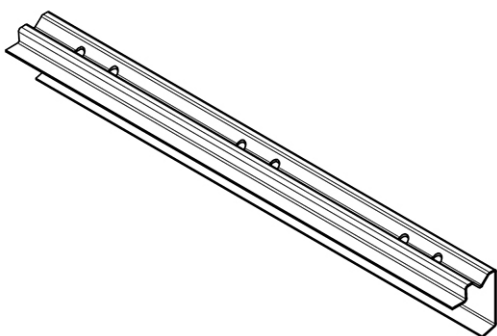

TT-number	Height of profile mm	Floor thickness B mm	Material thickness mm	L profile mm	Weight kg/m	Weight kg/pc
0451031.210	110	21	3.0	7500	6.3	47.2
0451031.270	110	27	3.0	7500	6.3	47.2
0451034.270	140	27	3.0	7500	7.0	52.5
0451031.018	Rubber blanking plug black, diameter 18, L = 20 mm					0.01



# FRAME PROFILES FOR FLATBED - STEEL

Perimeter profile, frame profile with holes for anchor shackles  
Material: S 355 MC

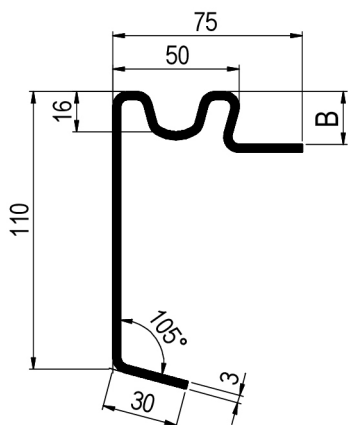
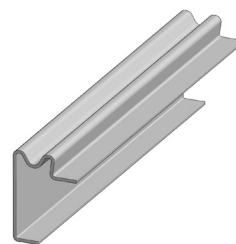
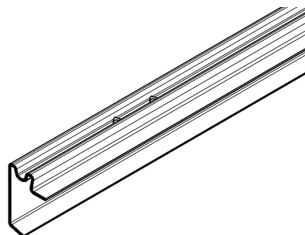
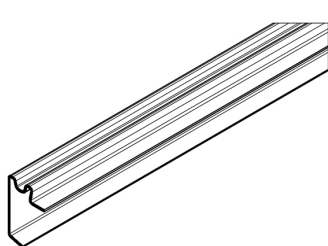

0451061.075  
0451062.075

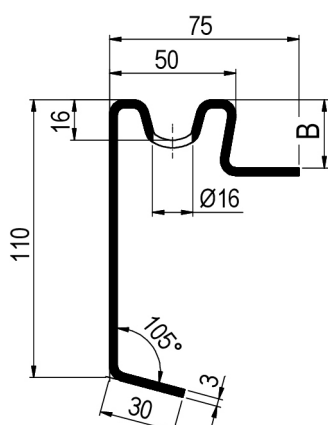

0451061.075D  
0451062.075D

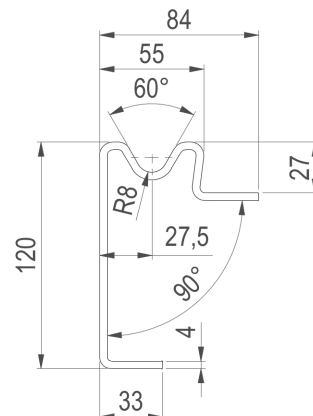

0451050.083

TT-number	Height of profile mm	Floor thickness B mm	Material thickness mm	L profile mm	Weight kg/m	Weight kg/pc
0451061.075	110	21	3.0	7500	5.65	42.4
0451061.075D	110	21	3.0	7500	5.65	42.4
0451062.075	110	27	3.0	7500	5.80	43.5
0451062.075D	110	27	3.0	7500	5.80	43.5
0451050.083	120	27	4.0	8350	8	67
0451031.016	Rubber blanking plug black, diameter 16 mm					

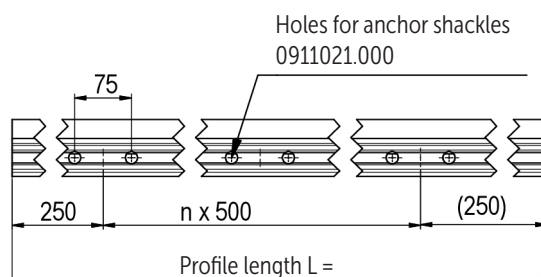

# FRAME PROFILES FOR TIPPER - ROLLED

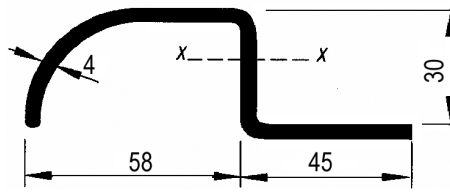

0451304.300

Frame profiles - Z - for tipper, rolled, material 11373 (St 37-2)						
TT-number	Floor thickness mm	Material thickness mm	L profile mm	Wx cm <sup>3</sup>	Wy cm <sup>3</sup>	Weight kg/m
0451303.300	30	3.0	6500	5.46	8.95	3.54
0451304.300	30	4.0	6000			4.42

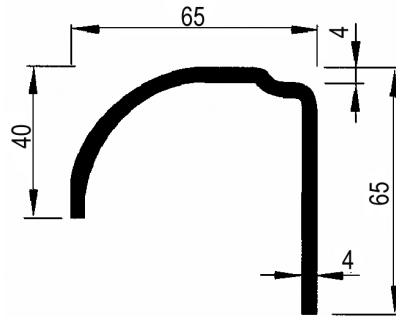

0451304.300

Frame profile for tipper, sheet metal floor, rolled, material 11373 (St 37-2)						
TT-number	Floor thickness mm	Material thickness mm	L profile mm	Wx cm <sup>3</sup>	Wy cm <sup>3</sup>	Weight kg/m
0451320.040	4	4.0	6000	4.07	7.52	4.30



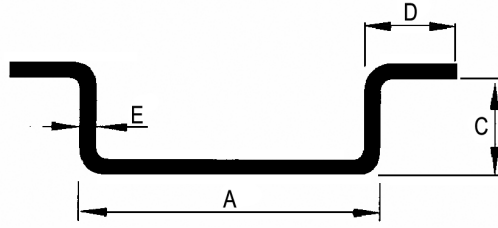

Omega profile, rolled, material 11373 (St 37-2)						
TT-number	Width A mm	Depth C mm	Dimension D mm	Material thickness E mm	L profile mm	Weight kg/m
0451408.280	80	28	28	4.0	4000	5.40
0451410.260	100	26	25	4.0	4000	5.75
0451410.310	100	31	30	5.0	4000	7.50
0451410.311	100	31	30	5.0	6000	7.50
0451410.350	100	35	30	5.0	4000	7.85



# SIDEBOARD PROFILES TYPE HV - STEEL, ROLLED

The HV type profiles are designed for use on agricultural tipper lorries, light flatbed lorries and dumper lorries.

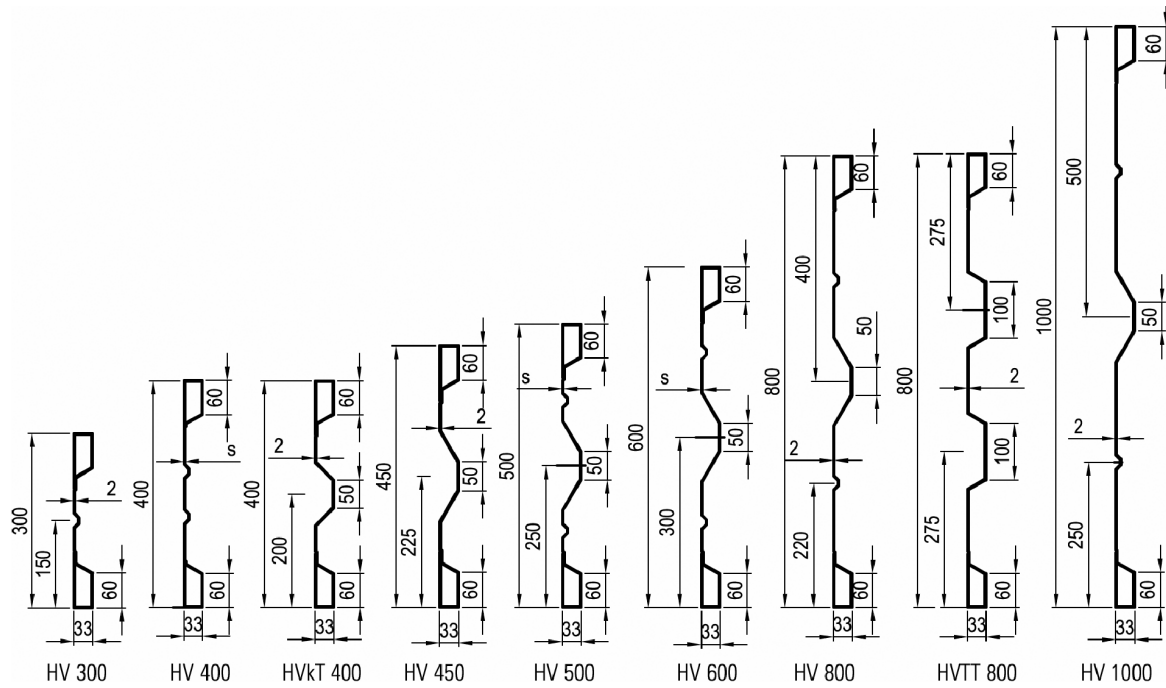

TT-number	Sideboard height mm	Name - type	Material thickness mm	Weight kg/m
0452040.125	400	Sideboard HV 400 x 1.25	1.25	6.73
0452040.150		Sideboard HV 400 x 1.5	1.5	8.01
0452040.200		Sideboard HV 400 x 2.0	2.0	10.68
0452040.201		Sideboard HVKT 400 x 2.0	2.0	10.98
0452040.202	450	Sideboard HV 450 x 2.0	2.0	11.61
0452050.150	500	Sideboard HV 500 x 1.5	1.5	9.31
0452050.200	500	Sideboard HV 500 x 2.0	2.0	12.40
0452060.150	600	Sideboard HV 600 x 1.5	1.5	10.48
0452060.200	600	Sideboard HV 600 x 2.0	2.0	13.97
0452080.200	800	Sideboard HV 800 x 2.0	2.0	17.11
0452080.201	800	Sideboard HVTT 800 x 2.0	2.0	17.68
0452100.200	1000	Sideboard HV 1000 x 2.0	2.0	20.25





# SIDEBOARD PROFILES TYPE HVN, HVAK - STEEL, ROLLED

The HVN type profiles with edging on the outside are suitable for use on agricultural tipper lorries, light flatbed lorries and P dumper lorries.

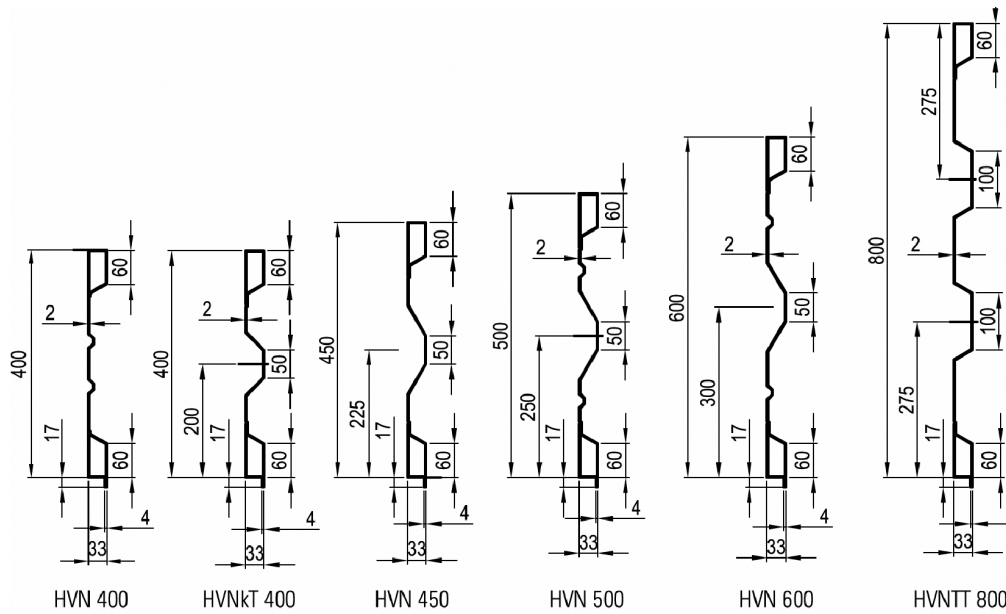

TT-number	Sideboard height mm	Name - type	Material thickness mm	Weight kg/m
0452041.200	400	Sideboard HVNKT 400 x 2.0	2.0	11.53
0452041.201	400	Sideboard HVN 400 x 2.0	2.0	11.23
0452041.202	450	Sideboard HVN 450 x 2.0	2.0	12.16
0452051.200	500	Sideboard HVN 500 x 2.0	2.0	12.95
0452061.200	600	Sideboard HVN 600 x 2.0	2.0	14.52
0452081.200	800	Sideboard HVNTT 800 x 2.0	2.0	18.14

HVAK type profiles with edging on the inside are suitable for use on agricultural lorries, light flatbed lorries and dumper lorries.

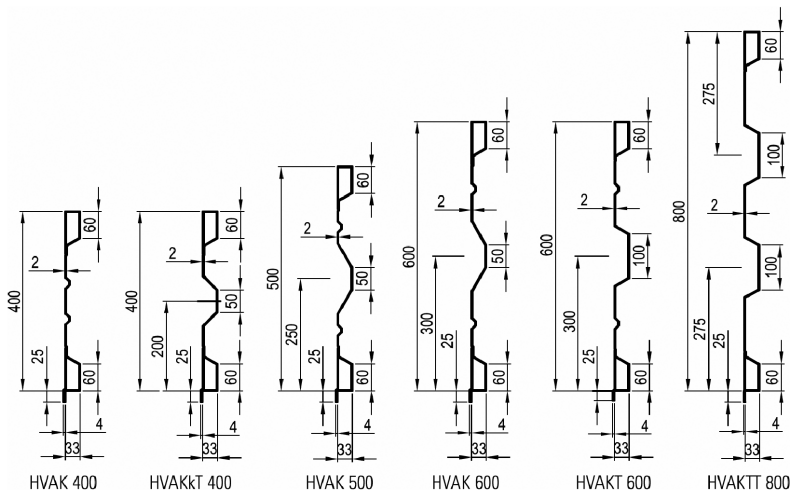

TT-number	Sideboard height mm	Name - type	Material thickness mm	Weight kg/m
0452042.200	400	Sideboard HVAKKT 400 x 2.0	2.0	11.64
0452042.201	400	Sideboard HVAK 400 x 2.0	2.0	11.34
0452052.200	500	Sideboard HVAK 500 x 2.0	2.0	12.95
0452062.200	600	Sideboard HVAK 600 x 2.0	2.0	14.63
0452062.201	600	Sideboard HVAKT 600 x 2.0	2.0	15.07
0452082.200	800	Sideboard HVAKTT 800 x 2.0	2.0	18.29



# SIDEBOARD PROFILES TYPE B, BN - STEEL, ROLLED

Sideboard profiles type B, BTT - steel, rolled with extended head

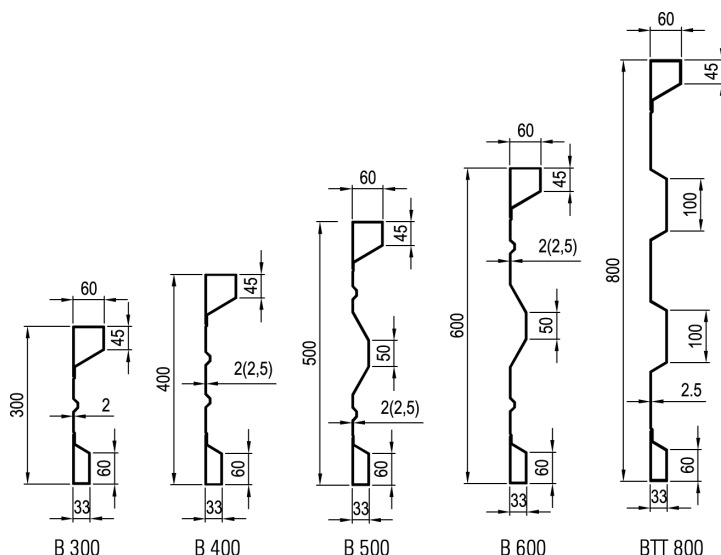

TT-number	Sideboard height mm	Name - type	Material thickness mm	Weight kg/m
0452034.200	300	Sideboard B 300 x 2.0	2.0	10.0
0452044.200	400	Sideboard B 400 x 2.0	2.0	11.6
0452054.200	500	Sideboard B 500 x 2.0	2.0	13.4
0452064.200	600	Sideboard B 600 x 2.0	2.0	15.0
0452084.250	800	Sideboard BTT 800 x 2.5	2.5	23.6

Sideboard profiles type BN - steel, rolled with extended head

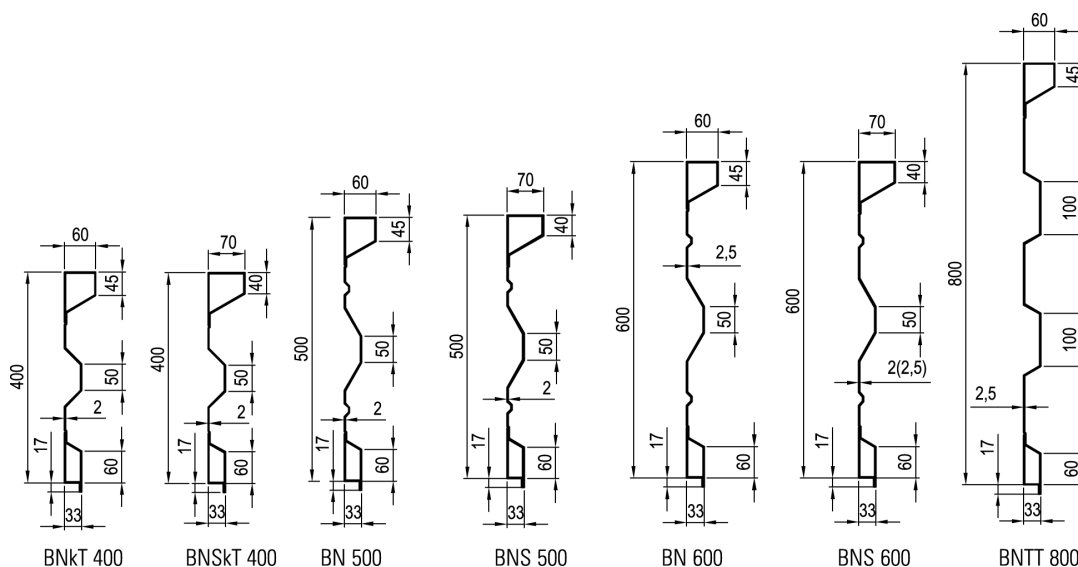

TT-number	Sideboard height mm	Name - type	Material thickness mm	Weight kg/m
0452045.260	400	Sideboard BNkT 400 x 2	2.0	12.3
0452045.270	400	Sideboard BNSkT 400 x 2	2.0	12.5
0452055.260	500	Sideboard BN 500 x 2	2.0	13.9
0452055.270	500	Sideboard BNS 500 x 2	2.0	14
0452065.260	600	Sideboard BN 600 x 2.5	2.5	19.3
0452065.270	600	Sideboard BNS 600 x 2.5	2.5	19.5
0452085.260	800	Sideboard BNTT 800 x 2.5	2.5	24.1



# SIDEBOARD PROFILES TYPE BAK - STEEL, ROLLED

Sideboard profiles type BAK - steel, rolled with extended head

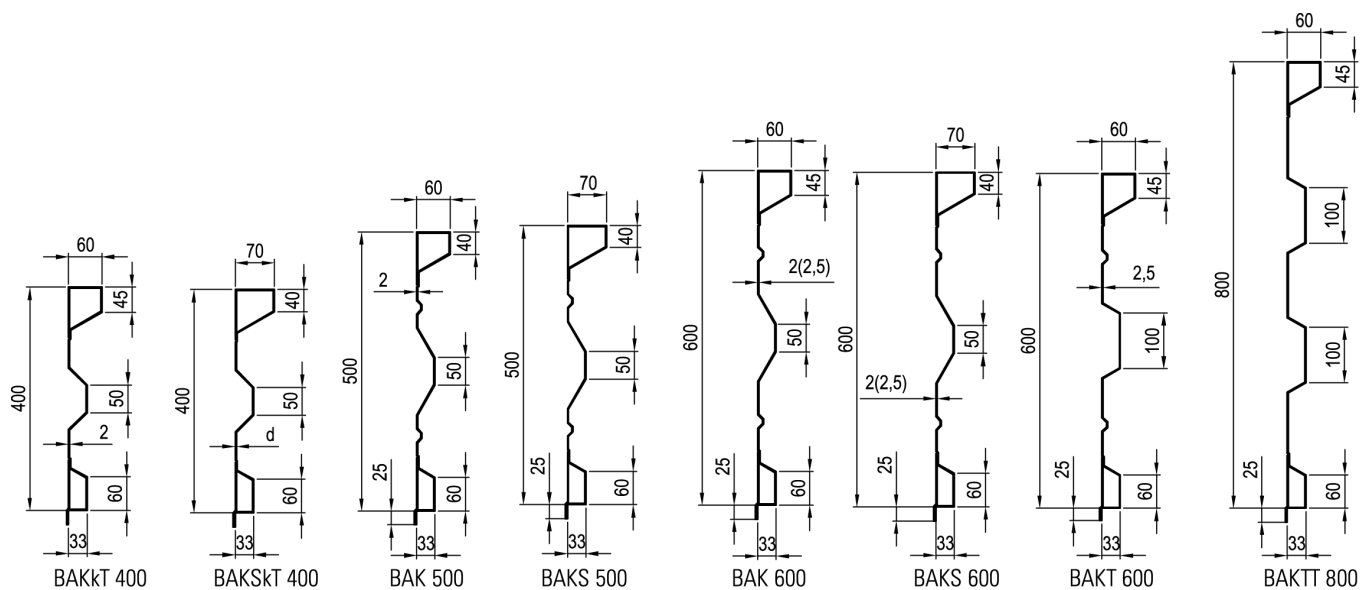

TT-number	Sideboard height mm	Name - type	Material thickness mm	Weight kg/m
0452043.260	400	Sideboard BAKKT 400 x 2	2	12.7
0452043.270	400	Sideboard BAKSKT 400 x 2	2	12.9
0452053.260	500	Sideboard BAK 500 x 2	2	14.2
0452053.270	500	Sideboard BAKS 500 x 2	2	14.4
0452063.260	600	Sideboard BAK 600 x 2.5	2.5	19.8
0452063.270	600	Sideboard BAKS 600 x 2.5	2.5	20.0
0452063.265	600	Sideboard BAKT 600 x 2.5	2.5	20.2
0452083.260	800	Sideboard BAKTT 800 x 2.5	2.5	24.8

